



Series 600

This Manual contains important information.
PLEASE READ PRIOR TO USE.



Calibration Line

WARRANTY

All products manufactured by Mensor® Corporation (Mensor) are warranted to be free of defects in workmanship and materials for a period of one year from the date of shipment. No other express warranty is given, and no affirmation of Seller, by words or actions, shall constitute a warranty. SELLER DISCLAIMS ANY IMPLIED WARRANTIES OF MERCHANTABILITY OR FITNESS FOR ANY PARTICULAR PURPOSES WHATSOEVER. If any defect in workmanship or material should develop under conditions of normal use and service within the warranty period, repairs will be made at no charge to the original purchaser, upon delivery of the product(s) to the factory, shipping charges prepaid. If inspection by Mensor or its authorized representative reveals that the product was damaged by accident, alteration, misuse, abuse, faulty installation or other causes beyond the control of Mensor, this warranty does not apply. The judgment of Mensor will be final as to all matters concerning condition of the product, the cause and nature of a defect, and the necessity or manner of repair. Service, repairs or disassembly of the product in any manner, performed without specific factory permission, voids this warranty.

MENSOR MAKES NO WARRANTY OF ANY KIND WITH REGARD TO THIS MANUAL, INCLUDING, BUT NOT LIMITED TO, THE IMPLIED WARRANTIES OF MERCHANTABILITY AND FITNESS FOR A PARTICULAR PURPOSE. Mensor shall not be liable for errors contained herein or for incidental or consequential damages in connection with the furnishing, performance, or use of this material.

IMPORTANT NOTICE

Please Note: The product specifications and other information contained in this manual are subject to change without notice.

Mensor Corporation has made a concerted effort to provide complete and current information for the proper use of the equipment. If there are questions regarding this manual or the proper use of the equipment, contact Mensor Corporation at:

TEL 1.512.396.4200
 TEL 1.800.984.4200 (USA only)
 FAX 1.512.396.1820

WEB SITE www.mensor.com
 E-MAIL sales@mensor.com
tech.support@mensor.com
quality@mensor.com

PACKAGING FOR SHIPMENT

If the product must be shipped to a different location or returned to Mensor for any reason through a common carrier it must be packaged properly to minimize the risk of damage.

The recommended method of packing is to place the instrument in a container, surrounded on all sides with at least four inches of shock attenuation material such as styrofoam peanuts.

FCC RADIO FREQUENCY EMISSION NOTICE

This equipment has been tested and found to comply with the limits for a Class A digital device, pursuant to Part 15 of the FCC Rules. These limits are designed to provide reasonable protection against harmful interference when the equipment is operated in a commercial environment. This equipment generates, uses, and can radiate radio frequency energy and, if not installed and used in accordance with the instruction manual, may cause harmful interference to radio communications. Operation of this equipment in a residential area is likely to cause harmful interference in which case the user will be required to correct the interference at his or her own expense.

USE SHIELDED CABLES TO CONNECT EXTERNAL DEVICES TO THIS INSTRUMENT TO MINIMIZE RF RADIATION.

WARNINGS AND CAUTION NOTES



WARNING: HIGH PRESSURE!

High pressure gases are potentially hazardous. Energy stored in these gases can be released suddenly and with extreme force. High pressure systems should be assembled and operated only by personnel who have been trained in proper safety practices.



WARNING: HIGH SOUND LEVELS!

Pressures from 600 psig and up can generate sound levels above 100 db for brief periods when they are exhausted directly to atmosphere. If no muffling devices are attached to the EXHAUST port, then ear protection is advised for personnel in the vicinity of instruments that will be operated under such conditions.



WARNING: POSSIBLE INJURY!

The tubing, valves and other apparatus attached to the gauge must be adequate for the maximum pressure which will be applied, otherwise physical injury to the operator or bystanders is possible.



WARNING: NOT EXPLOSION PROOF!

Installation of this instrument in an area requiring devices rated as intrinsically safe is not recommended.



CAUTION: Use the proper pressure medium. Use only clean, dry non-corrosive gases. This instrument is not designed for oxygen use.



CAUTION: ESD PROTECTION REQUIRED.

The proper use of grounded work surfaces and personal wrist straps are required when coming into contact with exposed circuits (printed circuit boards) to prevent static discharge damage to sensitive electronic components.

Additional Warning and Caution notes are included throughout this manual.

SOFTWARE LICENSE AGREEMENT

This product contains intellectual property, i.e., software programs, that are licensed for use by the end user/customer (hereinafter "end user").

This is not a sale of such intellectual property.

The end user shall not copy, disassemble or reverse compile the software program.

THE SOFTWARE PROGRAMS ARE PROVIDED TO THE END USER "AS IS" WITHOUT WARRANTY OF ANY KIND, EITHER EXPRESS OR IMPLIED, INCLUDING, BUT NOT LIMITED TO, WARRANTIES OF MERCHANTABILITY AND FITNESS FOR A PARTICULAR PURPOSE. THE ENTIRE RISK OF THE QUALITY AND PERFORMANCE OF THE SOFTWARE PROGRAM IS WITH THE END USER.

MENSOR AND ITS SUPPLIERS SHALL NOT BE HELD TO ANY LIABILITY FOR ANY DAMAGES SUFFERED OR INCURRED BY THE END USER (INCLUDING, BUT NOT LIMITED TO, GENERAL, SPECIAL, CONSEQUENTIAL OR INCIDENTAL DAMAGES INCLUDING DAMAGES FOR LOSS OF BUSINESS PROFITS, BUSINESS INTERRUPTION, LOSS OF BUSINESS INFORMATION AND THE LIKE), ARISING FROM OR IN CONNECTION WITH THE DELIVERY, USE OR PERFORMANCE OF THE SOFTWARE PROGRAM.

TRADEMARKS / COPYRIGHT (C)

Mensor is a registered trademark of Mensor Corporation. All other brand and product names are trademarks or registered trademarks of their respective companies.
©2006, Mensor Corporation. All rights reserved.

Korean font: Copyright (C) 1987, 1988; Daewoo Electronics Co., Ltd.

Chinese font: Copyright (C) 1988; The Institute of Software, Academia Sinica.
Correspondence address: P.O. Box 8718, Beijing, China 100080.

MENSOR BACKGROUND

HISTORY: Mensor is an ISO-9001:2000 certified manufacturer of precision pressure products. Mensor was established in 1969 in Houston, Texas as an independent spin-off from the Texas Instruments (TI) Pressure Instrument Group. As a private corporation, Mensor's objective was to design and produce high accuracy, high quality, easy to use pressure instruments. In 1978 Mensor moved to its present location in San Marcos, on Interstate 35 (the Austin-San Antonio corridor). Two and a half years after the move, the plant was destroyed by fire on Friday, February 13, 1981. Mensor resolved to come back, and almost before the ashes had cooled, construction of a new building began on the same site. Six months after the disaster Mensor moved into its present facility and began shipping products to customers who had waited patiently for the recovery.

PEOPLE: The key to Mensor's strength in the marketplace is the concentration of experienced people in the field of precision pressure measurement and control. The company's founders previously worked in various capacities in the Pressure Instrument Group of Texas Instruments, including engineering, production and marketing. These founders were involved in the design of the original quartz bourdon pressure gauge at TI. Mensor's CEO, Jerry Fruit, is co-holder of the patent on using a fused quartz bourdon tube to accurately measure pressure. Mensor full time employees have an average tenure of 16 years. That's a lot of pressure experience!

PRODUCTS: Mensor's portfolio of products consists of an extensive line of precision pressure instruments, including digital gauges, pressure controllers, transducers and pressure calibrations systems. All of these products feature computer interface capability. These products are used in metrology labs, calibration labs, research facilities, engineering offices, production test stands, and in other environments where high accuracy pressure measurement and/or control is required. Many of these products include customized features to meet a customer's specific requirement. Mensor product costs range from about \$900 to \$30,000.

CUSTOMERS: Typical Mensor customers are pressure sensor manufacturers, aerospace firms, jet engine manufacturers, electric utilities, nuclear power plants, pharmaceutical firms, calibration laboratories, government agencies and research organizations.

APPLICATIONS: In many facilities the highest accuracy pressure measuring or pressure controlling instrument is a Mensor product. A typical application for these Mensor instruments is the calibration of other pressure devices, such as sensors, transducers, transmitters, gauges and pressure switches. The Mensor product is used as the pressure standard to verify pressure calibrations or outputs of the device being produced, checked, tested or certified.



TABLE OF CONTENTS

Warranty	ii
Important Notice	ii
Packaging for Shipment	ii
FCC Radio Frequency Emission Notice	ii
Warnings and Caution Notes	iii
Software License Agreement	iii
Trademarks/Copyrights	iii
Mensor Background	iv

SECTION 1: INTRODUCTION

Did you get everything?	1-1
Initial Inspection	1-1
Meet your APC 600	1-1
Features	1-2
Front Panel	1-2
Display	1-3
Electrical Module	1-4
Pneumatic Module	1-5
Rear Panel	1-6
Chassis Assembly	1-7
Electrical Block Diagram	1-8
Power Up!	1-8
Mensor Service Plus	1-8
After the Warranty	1-9
Calibration Services	1-9
Accreditations	1-9

SECTION 2: INSTALLATION

Mounting	2-1
Pressure Connections	2-1
Supply Port	2-1
Measure/Control Port	2-2
Exhaust Port	2-2
Reference Port	2-2
Remote Bus Connections	2-2
Digital I/O Connection	2-2
Power On	2-2

SECTION 3: LOCAL OPERATION

General	3-1
Keys and Tabs	3-2
Display Screen Features	3-2
[Mensor] Logo	3-2
[Flag] Symbol	3-2
[>] and [<] Keys	3-3
Turndown Label and [Range Selector] Key	3-3
Pressure Label	3-3
Pressure [Units] Key	3-4
[Step Value] Key	3-4

Step Down [v] and Step Up [^] Keys	3-4
Control Pressure [Setpoint Value]	3-5
Remote Setup	3-5
[Program] Key	3-6
Editing or Creating a Program	3-7
Running a Program	3-8
[Local] Label	3-9
[Setup] Key	3-9
[Channel] Setup	3-9
[Sensor] Setup	3-10
[Controller] Setup	3-10
Low Range Pressure Regulator	3-11
Mid Range Pressure Regulator	3-12

SECTION 4: REMOTE OPERATION

Remote Setup	4-1
Ethernet Communication	4-2
IEEE-488 (GPIB)	4-2
Capability Codes	4-2
Interface Functions	4-3
RS-232 Serial Communication	4-3
Cable Requirements	4-3
Command/Query Format	4-3
Command Set Definitions	4-4
Output Formats	4-4
Command/Query List	4-4
APC 600 Commands and Queries	4-5
APC 600 Error Codes	4-10
SCPI Commands	4-12
Output Format	4-14
Error Codes	4-14
Remote Emulation	4-15
PCS 400 Emulated Commands/Queries	4-16
PCS 200 Emulated Commands/Queries	4-17

SECTION 5: MAINTENANCE

Beyond the Warranty	5-1
Troubleshooting the Pneumatic System of the APC 600	5-1
Low Range Pressure Regulator	5-1
Pneumatic Schematic - Low Range Regulator	5-2
Mid Range Pressure Regulator	5-3
Tuning a Mid Range Regulator Module	5-3
Regulator Valves	5-3
Pneumatic Schematic - Mid Range Pressure	5-4
Pneumatic Module Solenoids	5-5
Replacing Modules	5-5
Transducer Removal	5-5
Transducer Installation	5-6
Pneumatic Module Removal	5-6
Pneumatic Module Installation	5-6
Spare Parts List	5-6
Chassis Interior, Top View	5-7
Chassis Interior, Front View	5-8

SECTION 6: CALIBRATION

General 6-1
 Environment 6-1
 Pressure Standards 6-1
 Media 6-1
 Setup 6-1
 Password 6-3
 Change Password 6-3
 Restoring a Mensor Calibration 6-4
 On-site Calibration 6-4
 Procedure for on-site Calibration 6-4
 APC 600 Preparation 6-4
 [Calibrate] Setup Key 6-5
 One Point Calibration 6-7
 Two Point Calibration 6-8
 Head Pressure Correction 6-9

SECTION 7: SPECIFICATIONS

7-1

SECTION 8: OPTIONS

Transport Case 8-1
 Rack Mount Kit 8-1
 Calibration Sled Kit 8-1
 Additional Transducers 8-2
 Secondary Transducer Installation 8-2
 Barometric Reference Transducer 8-2
 Gauge Pressure Emulation Key 8-2
 Absolute Pressure Emulation Key 8-2
 Calibration 8-2
 Specifications 8-2
 Virtual Delta Channel 8-3
 Delta Functions 8-3
 Screen Source 8-3
 Configure Button 8-3
 Slave Channel Display 8-3
 Screen Source A B 8-3
 Screen Source A Delta 8-3
 Screen Source Delta B 8-4
 Delta Control Limits 8-4
 Delta Units Type 8-4
 Setup Screens 8-4
 New Commands 8-4

SECTION 9: APPENDIX

Measurement Units 9-1
 Conversion Factors, PSI 9-2
 Conversion Factors, Millitorr 9-3
 Conversion Factors, Pascal 9-4

Reference List of Figures

Figure 1.1 - Front Panel	1-1
Figure 1.2 - Internal Access	1-2
Figure 1.3 - Terminology of Screen Elements	1-3
Figure 1.4 - Electrical Module - Top View	1-4
Figure 1.5 - Pneumatic Modules	1-5
Figure 1.6 - Rear Panel	1-6
Figure 1.7 - Chassis Assembly	1-7
Figure 1.8 - Electrical Block Diagram	1-8
Figure 1.9 - Typical Operating Screen	1-9
Figure 1.10 - Basic Display Information	1-9
Figure 2.1 - Rear Panel	2-1
Figure 2.2 - Digital I/O Connection	2-2
Figure 3.1 - Display Screen Features	3-1
Figure 3.2 - Typical Operation Screen	3-2
Figure 3.3 - Language Selection Window	3-2
Figure 3.4 - [Range Selector] Key	3-3
Figure 3.5 - [Range Selector] drop-down Menu	3-3
Figure 3.6 - Units Selection Window	3-4
Figure 3.7 - Step Value Window (Single Channel)	3-4
Figure 3.8 - [Setpoint Value] Window)	3-5
Figure 3.9 - Main Program Screen	3-6
Figure 3.10 - Program Selection Screen	3-6
Figure 3.11 - Program Editing Screen	3-7
Figure 3.12 - Keyboard Screen	3-7
Figure 3.13 - Program Line Edit Screen	3-8
Figure 3.14 - Main Operation Screen in Program Mode	3-8
Figure 3.15 - Channel Setup Screen	3-9
Figure 3.16 - Status Screen	3-10
Figure 3.17 - Sensor Setup Screen	3-10
Figure 3.18 - Resolution Window	3-10
Figure 3.19 - Controller Setup - Low Range Pressure	3-11
Figure 3.20 - Stable Limit Window	3-11
Figure 3.21 - Control Limits Window	3-11
Figure 3.22 - Stable Delay Window	3-11
Figure 3.23 - Controller Setup, Mid Range	3-12
Figure 4.1 - [Remote] Key	4-1
Figure 4.2 - [Instrument] Key	4-1
Figure 4.3 - [IEEE-488] Key	4-1
Figure 4.4 - [Serial] Key	4-2
Figure 4.5 - [Ethernet] Key	4-2
Figure 4.6 - Serial Cable	4-3
Figure 5.1 - Test Screen, Low Pressure	5-1
Figure 5.2 - Pneumatic Module, Low Pressure	5-1
Figure 5.3 - Pneumatic Schematic, Low Range Pressure	5-2
Figure 5.4 - Test Screen, Mid Pressure	5-3
Figure 5.5 - Tune Screen, Mid Pressure	5-3
Figure 5.6 - Pneumatic Schematic, Mid Range Pressure	5-4
Figure 5.7 - Pneumatic Module, Mid/High Range Pressure	5-5
Figure 5.8 - Chassis Interior, Top View	5-7
Figure 5.9 - Chassis Interior, Front View	5-8
Figure 6.1 - Calibration Setup	6-2
Figure 6.2 - Locked Calibration Data Screen	6-3
Figure 6.3 - 'Enter Password' Window	6-3

Figure 6.4 - Unlocked Calibration Data Screen	6-3
Figure 6.5 - 'Change Password' Window	6-4
Figure 6.6 - Calibrate Screen (locked)	6-5
Figure 6.7 - Calibrate Screen (unlocked)	6-5
Figure 6.8 - Date of Calibration (DOC) Window	6-5
Figure 6.9 - Autozero	6-6
Figure 6.10 - Autozero Window	6-6
Figure 6.11 - '1 Point Cal' Key	6-7
Figure 6.12 - '1 Point Cal' Window	6-7
Figure 6.13 - '2 Point Cal' Key	6-8
Figure 6.14 - 'Low Point Cal' Window	6-8
Figure 6.15 - 'High Point Cal' Window	6-8
Figure 6.16 - 'DOC' Window	6-8
Figure 6.17 - Head Correction	6-9
Figure 6.18 - Height, Head Correction	6-9
Figure 6.19 - Gas Density, Head Correction	6-9
Figure 6.20 - Gas Temperature, Head Correction	6-9
Figure 6.21 - Local Gravity, Head Correction	6-9
Figure 7.1 - APC 600 Dimensions	6-10
Figure 8.1 - Transport Case	7-2
Figure 8.2 - Rack Mount Kit	8-1
Figure 8.3 - Calibration Sled Kit	8-1
Figure 8.4 - Configure Button Display Screen	8-1
Figure 8.5 - Screen Source A Delta	8-3
Figure 8.6 - Screen Source Delta B	8-3

Reference List of Tables

Table 4.1 - APC 600 Remote Commands and Queries	4-5
Table 4.2 - Error Codes (APC 600)	4-10
Table 4.3 - Error Codes (SCPI Commands)	4-14
Table 4.4 - PCS 400 Emulated Commands/Queries	4-16
Table 4.5 - PCS 200 Emulated Commands/Queries	4-17
Table 5.1 - Spare Parts	5-6
Table 9.1 - Measurement Units	9-1
Table 9.2 - Conversion Factors, PSI	9-2
Table 9.3 - Conversion Factors, Millitorr	9-3
Table 9.4 - Conversion Factors, Pascal	9-4

User's Notes:

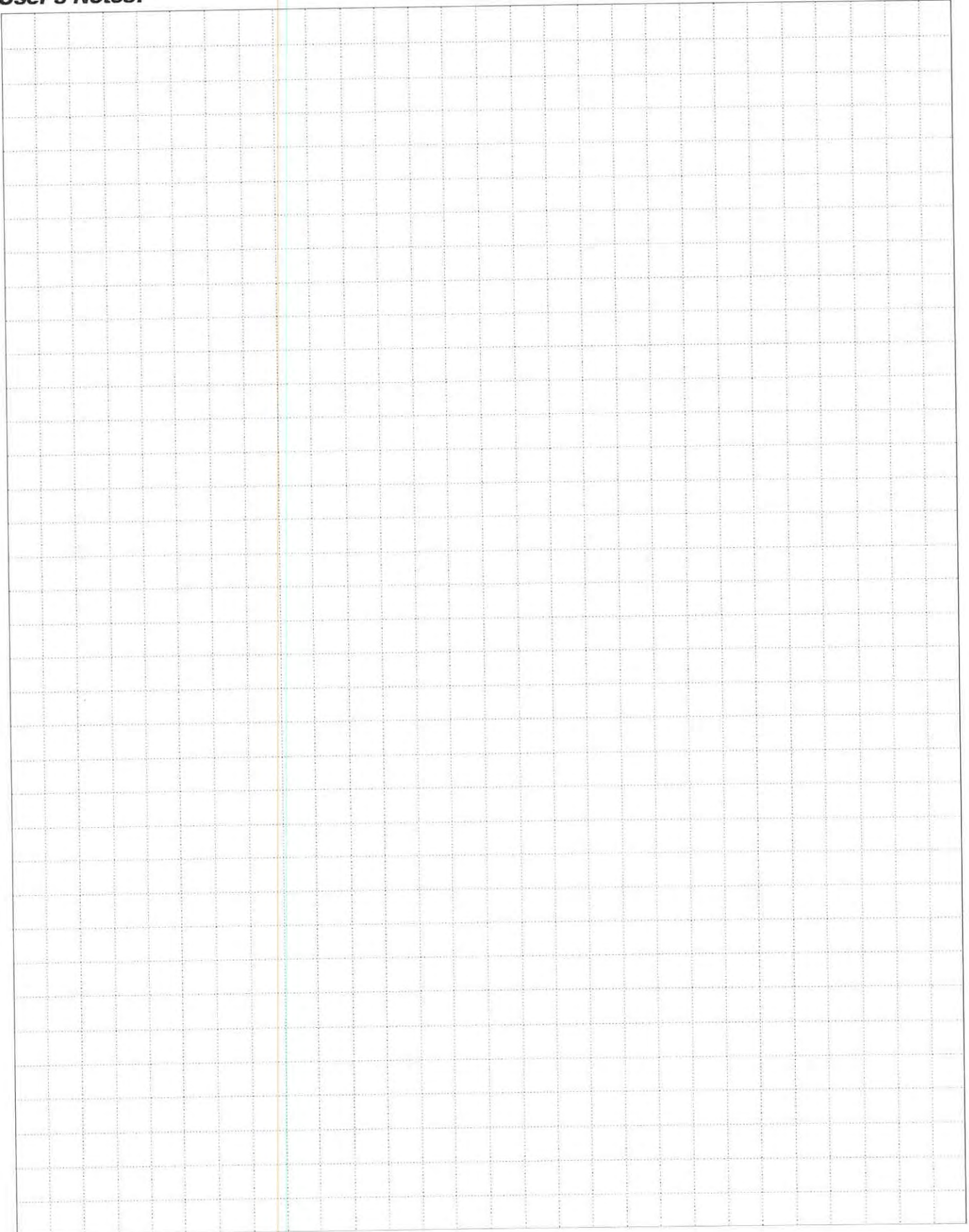

Section 1: INTRODUCTION

DID YOU GET EVERYTHING?

In addition to this manual you should have:

- Series 600 Automated Pressure Calibrator
- Power cord
- 1/8 inch FNPT fitting adapters fastened to rear panel
- Any accessories ordered
- Envelope containing a Calibration Certificate

INITIAL INSPECTION

Your new instrument was subjected to many hours of functional testing before it left the factory. In addition to testing, the unit was inspected for appearance prior to being packaged for shipment. Upon removal from its carton please examine the instrument for shipping damage. Report any apparent damage to the carrier immediately.

MEET YOUR APC 600

The Mensor Series 600 Automated Pressure Calibrator (APC 600) is a multi-channel/multi-range pressure system designed to test and calibrate a variety of pressure devices in either absolute or gauge pressure modes. The APC 600 can have two independent control channels each with its own pressure regulator. Each control channel can have two transducers, and each transducer can have two turn-downs. Thus, a fully configured APC 600 is capable of having 8 native ranges and 8 emulated ranges (with optional barometric reference) for a total of 16 pressure ranges.



Figure 1.1 - Front Panel

Features

Here is a short list of significant features designed into the APC 600:

1. Up to four (two per channel) highly stable, temperature compensated, pressure transducers. Each transducer can have two ranges (turndowns);
2. An optional internal high accuracy barometric reference transducer provides gauge pressure emulation for all of the absolute ranges and absolute pressure emulation for gauge ranges;
3. All pressure transducers are individually removable from the front of the APC 600 without the use of tools (excluding the barometric transducer). This feature greatly facilitates "out of instrument" recalibration of individual transducers using the optional Calibration Sled (see *Options*, Section 8);
4. Two precision pressure regulators are selectable for controlled output pressure. These regulators have a history of excellent control and stability;
5. A separate electrical module using a high speed microprocessor. The operating program is loaded from a non-volatile flash disk;
6. A large color SVGA LCD display with a touch screen for intuitive operator interface;
7. Multiple languages; change the language for on-screen text and number/date formats instantly by simply touching one of the "national flag" cues available on the display (see Figure 3.3). The current language selections available are listed in the *Local Operation* section under "[Flag] Symbol".

Operate the APC 600 while it is either sitting on a bench or mounted in a standard equipment rack. Leveling the instrument is not a consideration since the pressure sensors are not affected by orientation. Use either front panel input (*Local Operation*), or send commands and queries over a bus from a separate "host" controller (*Remote Operation*).

Front Panel

The APC 600 front panel (Figure 1.1) includes an 8.4 inch color SVGA display featuring touch screen technology. Operator input is accomplished by pressing the words or symbols presented on the display. There are no discrete keypads or switches on the front panel.

On the right hand side of the front panel, under the Mensor logo, there is a clear window which shows the calibrated pressure ranges of the internal transducers and the instrument serial number.

To gain access to the internal modules simply loosen the two thumb screws on the right hand edge of the front panel and swing it open (Figure 1.2). In the front of the instrument directly below the electrical module are slots to accommodate two pressure transducer modules on each control channel. Each transducer can be removed and reinstalled through the front panel opening. See Section 5, *Maintenance*, for additional information on module removal and replacement.



Figure 1.2 - Internal Access

Display

When the APC 600 is powered up it takes about one minute for initialization, then displays a screen similar to Figure 1.3. The display is made up of rectangles which display text or symbols.

Keys, Tabs, Labels and Windows: In this manual a key is a small rectangle which acts as a switch when pressed. Keys have borders with a three dimensional, shadowed effect. Tabs are a group of touch points, each of which will overlay most of the screen with one page related to its title subject. Small rectangles with solid borders that display information, but do not respond to being touched, are called Labels or Windows.

Keys: Keys cause something to change when they are touched. Throughout this manual keys are represented with the displayed characters enclosed in brackets such as [PSI A]. Each key has a characteristic response when actuated; either an instant, single step response when the key is pressed, or continuously repeating steps while the key is held down, or a delayed response when released. Operators will quickly become accustomed to the particular characteristics of the frequently used keys. Some keys become labels under certain con-

ditions, then resume their key function in other circumstances.

Header Bar: The bar across the top of the screen which displays the Mensor Logo, a title frame, and a national flag is stationary and remains displayed at all times. All of the number formats and text displayed on the APC 600 screens will be in the language appropriate to the national flag displayed here such as American English for the USA flag, etc. Touch the flag to access a drop-down window showing all of the languages programmed into the APC 600. Touch any flag to change the display to the corresponding language.

Optional Display: The optional display is a window near the pressure label. This window can be set up to be blank, or to display any one of the following:

- Peak Pressure – minimum and maximum
- Rate of change of a measured pressure
- Barometer reading

Footer Keys: Like the top bar, the [Remote] and [Program] keys on the bottom left corner of the display remain permanently on-screen. Touch either of these keys cause that subject page to appear in the display.

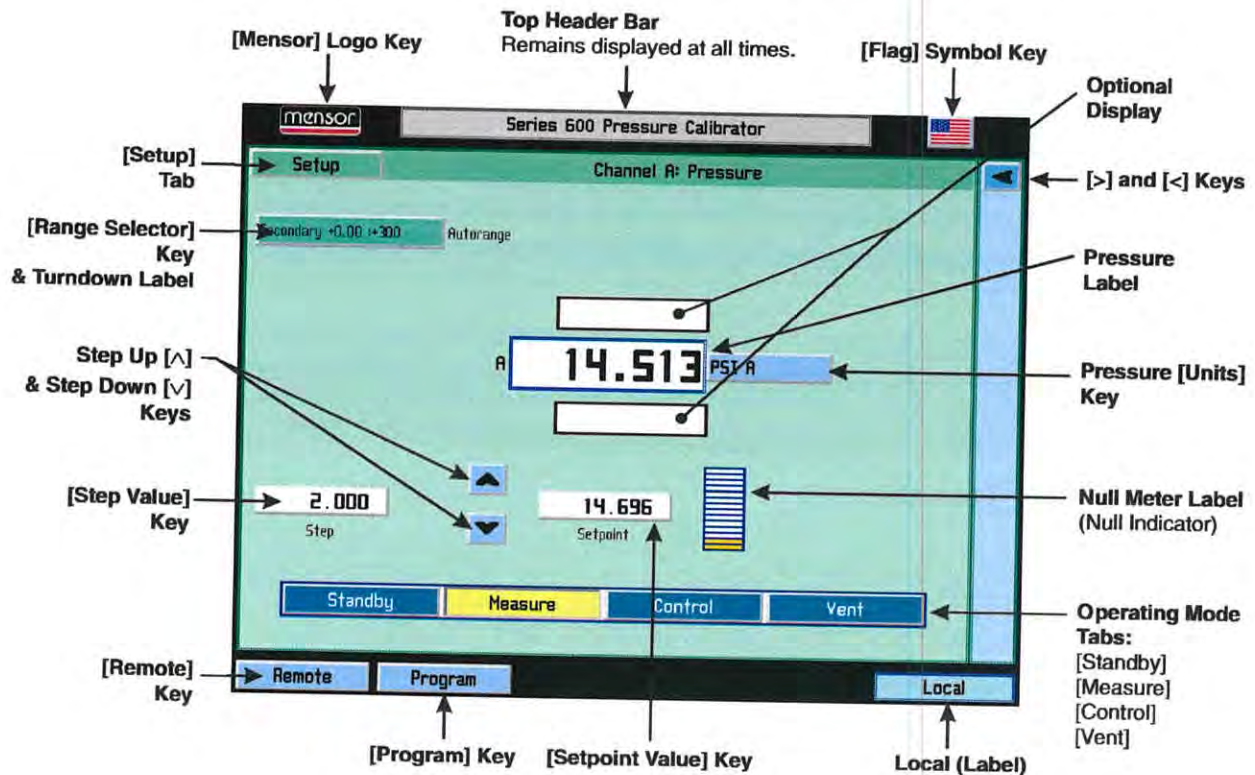

Figure 1.3 - Terminology of Screen Elements

Electrical Module

The electrical module is illustrated below with the instrument lid removed (Figure 1.4). All program information to run the system resides on a solid state disk module located on this module. The power switch and line fuses are situated on the rear of the electrical module such that they are accessible on the rear of the fully assembled APC 600.

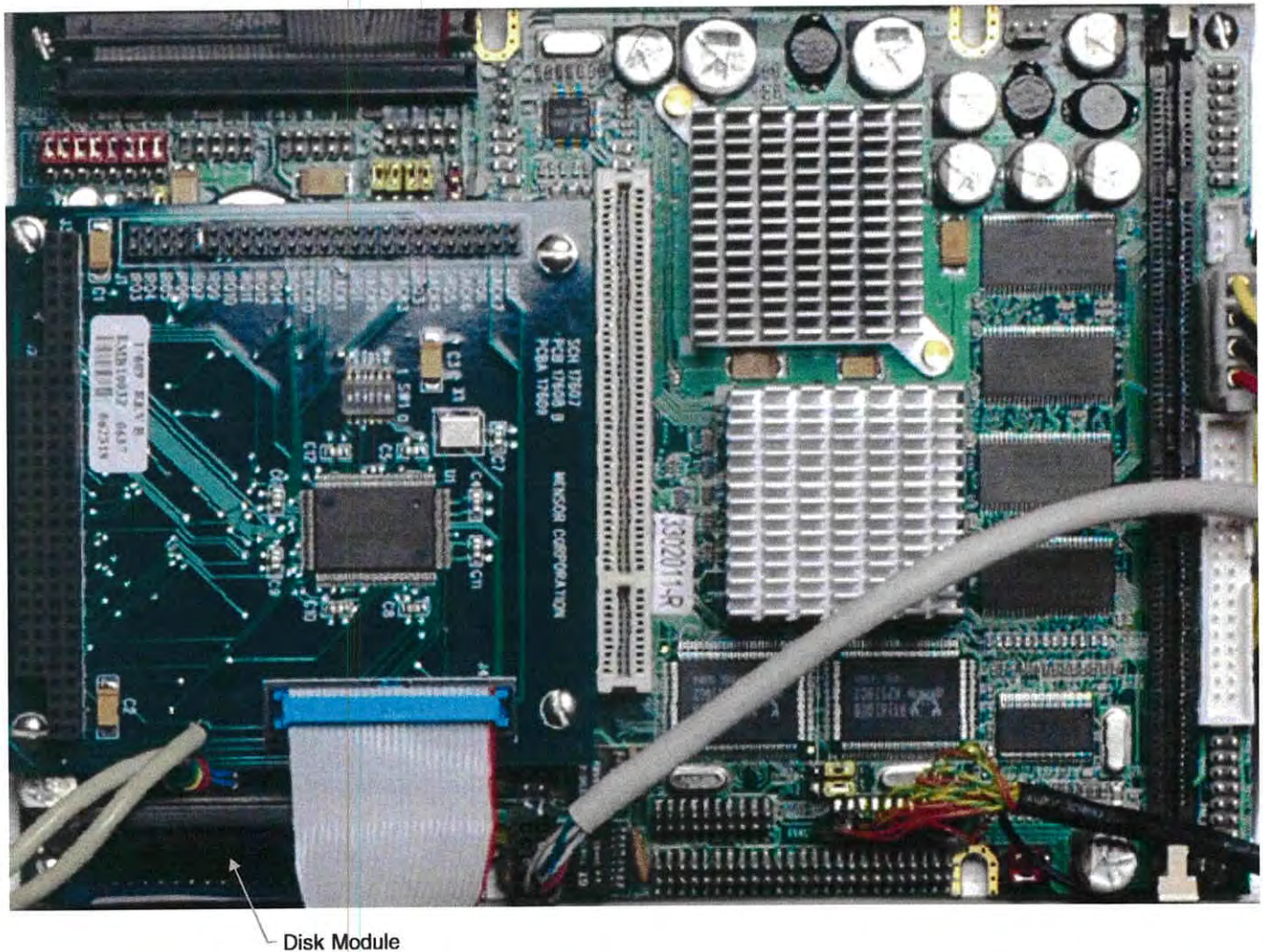

Figure 1.4 - Electrical Module-Top View

Pneumatic Module

Each pneumatic module (Figure 1.5) includes platforms for up to two high performance pressure transducers which are traceable to NIST standards. Both of these transducers can be used in conjunction with the highly stable pressure regula-

tor to produce a precise pressure output. Each transducer includes its own on-board compensation and calibration data so that any transducer can be replaced in the instrument without requiring a recalibration.

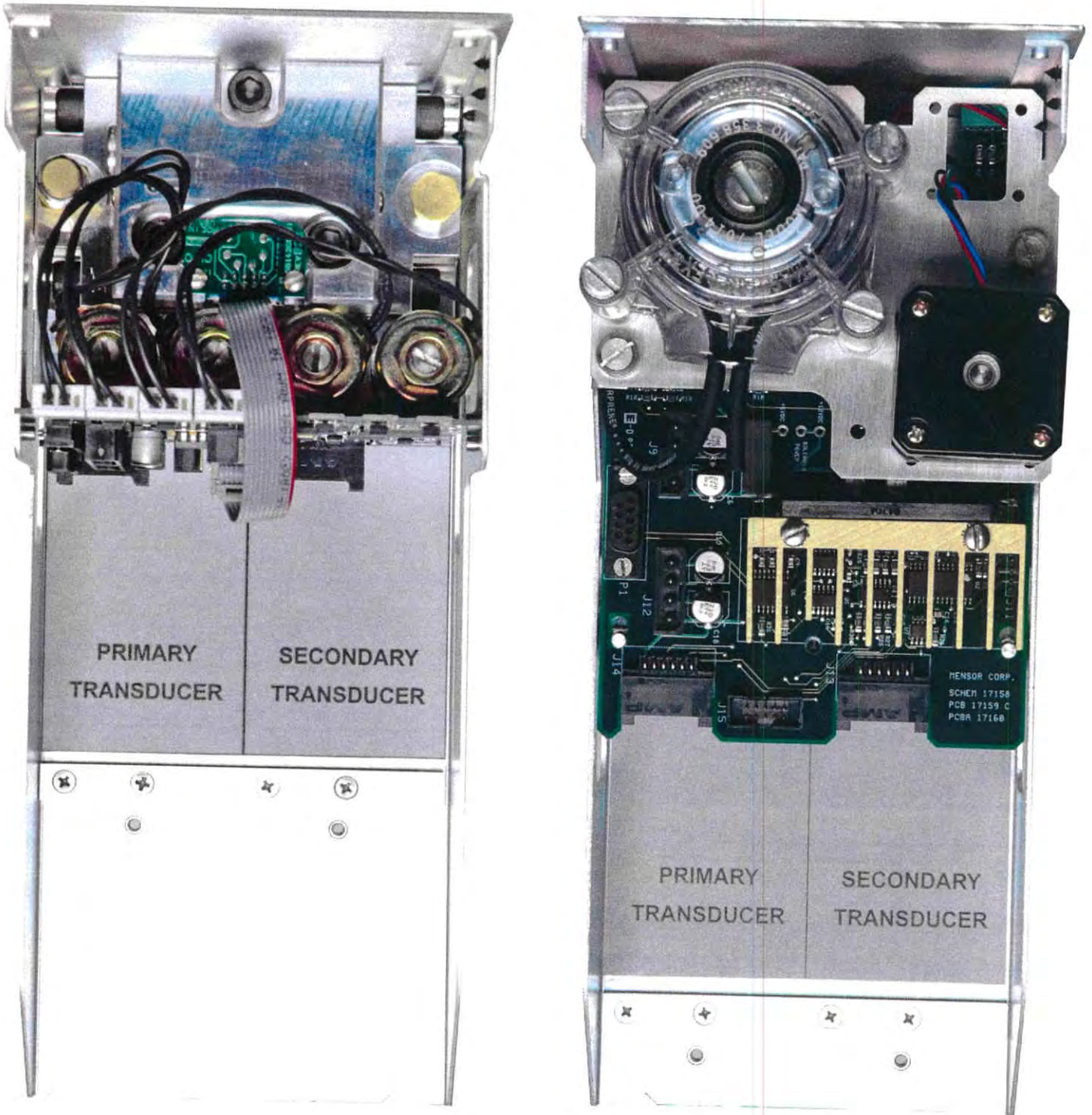

Figure 1.5 - Pneumatic Modules

Rear Panel

Up to eight pneumatic pressure ports are located horizontally across the rear panel (Figure 1.6). Positioned to the right of the pressure ports are the ethernet and RS-232 and GPIB connector, the off/on switch, the line fuses, and a protective grill covering the ventilating fan.

Figure 1.6 shows a rear panel containing 2 mid range pneumatic modules. Rear panels may differ depending on what modules are installed.

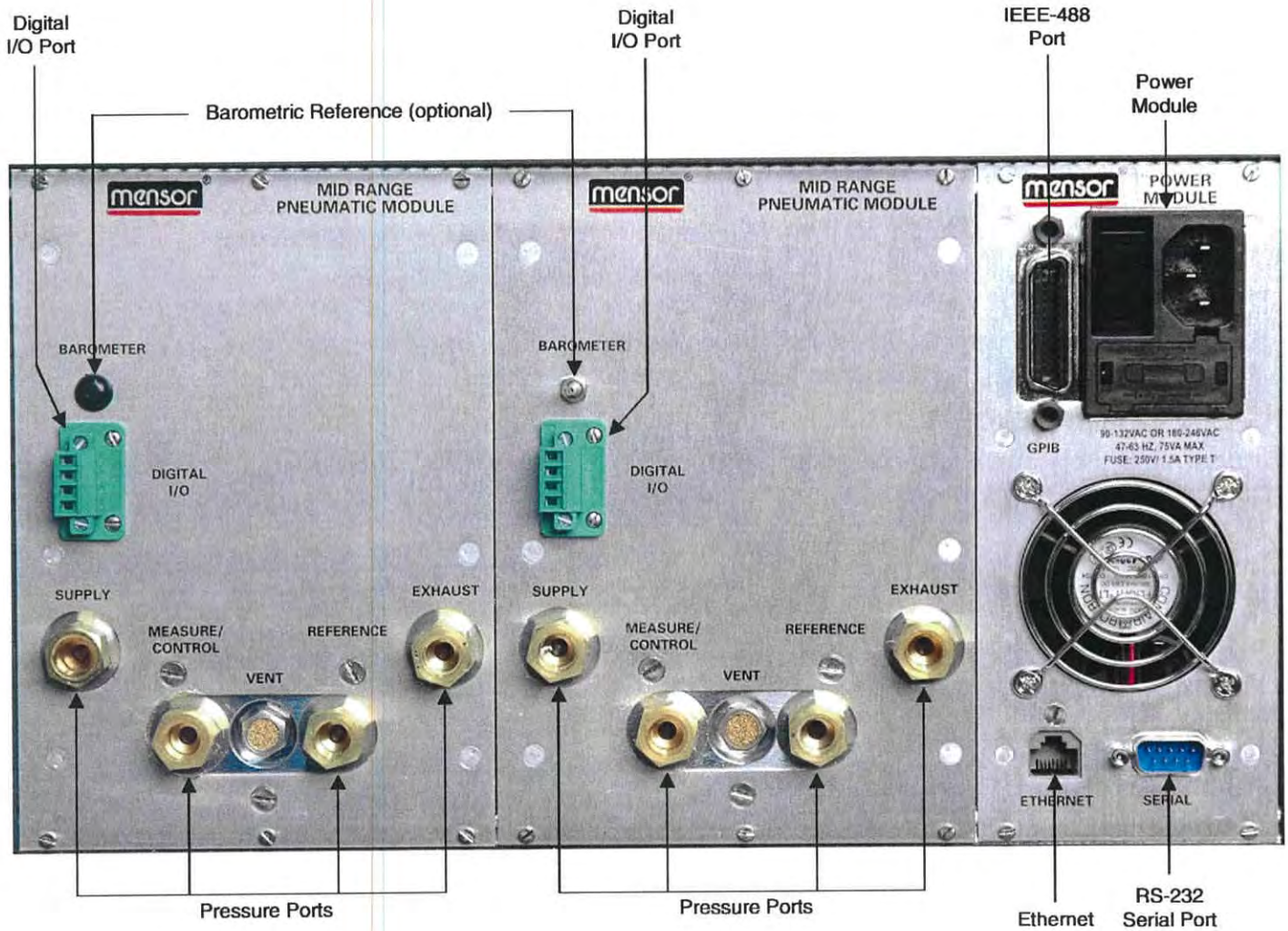

Figure 1.6 - Rear Panel

Chassis Assembly

The chassis assembly acts as the housing for the system. The electrical and pneumatic modules are each self-contained inside the chassis, and either can be replaced using basic hand tools. In addition, each pressure transducer is individually removable without tools. Instructions for transducer and module removal are provided in Section 5, *Maintenance*.

The only moving parts in the APC 600 are the fan, the pneumatic flow controller diaphragms and valves, the pump/motor, and the solenoid valve plungers. There are no internal user adjustments or setup switches.

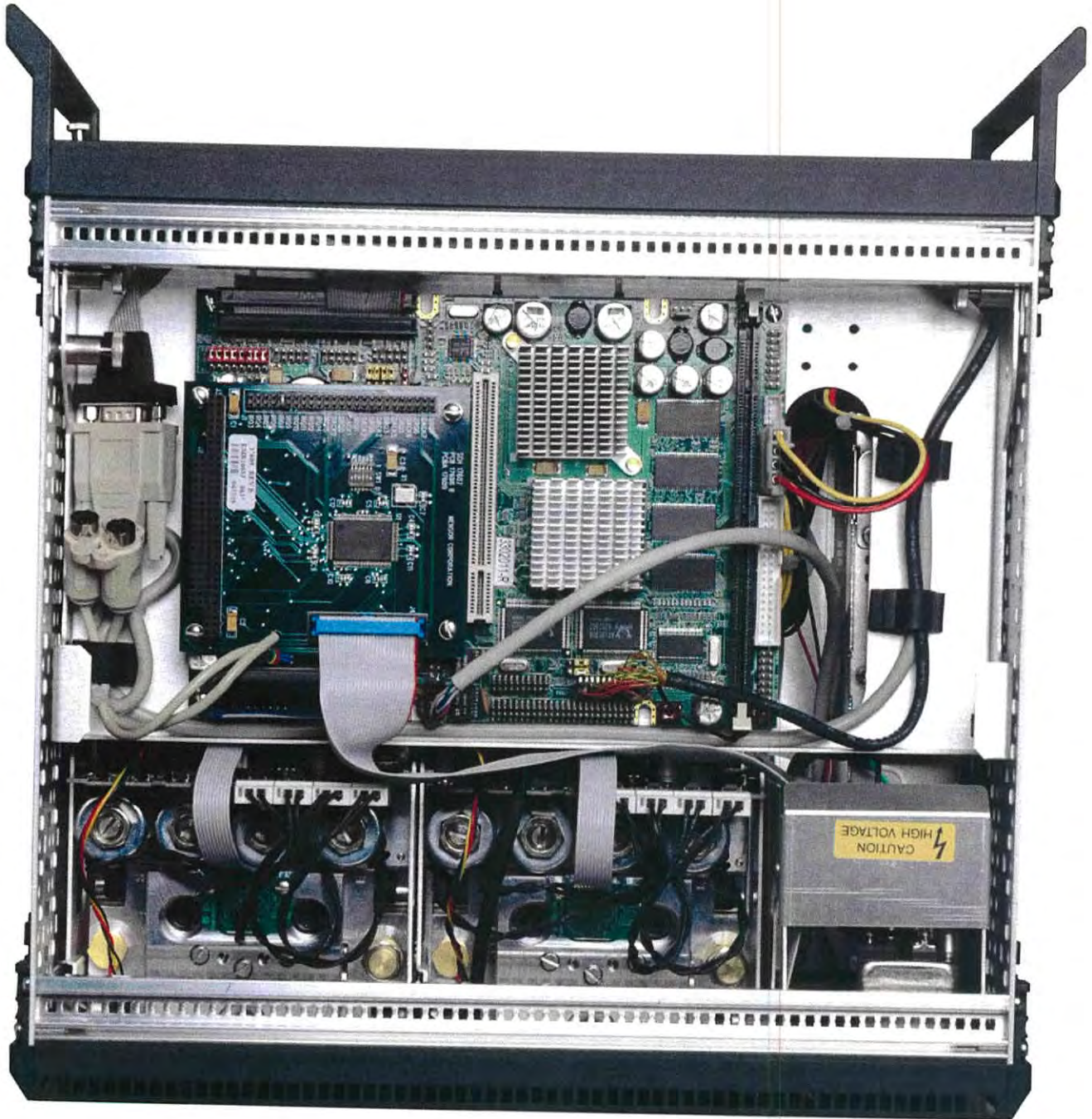

Figure 1.7 - Chassis Assembly

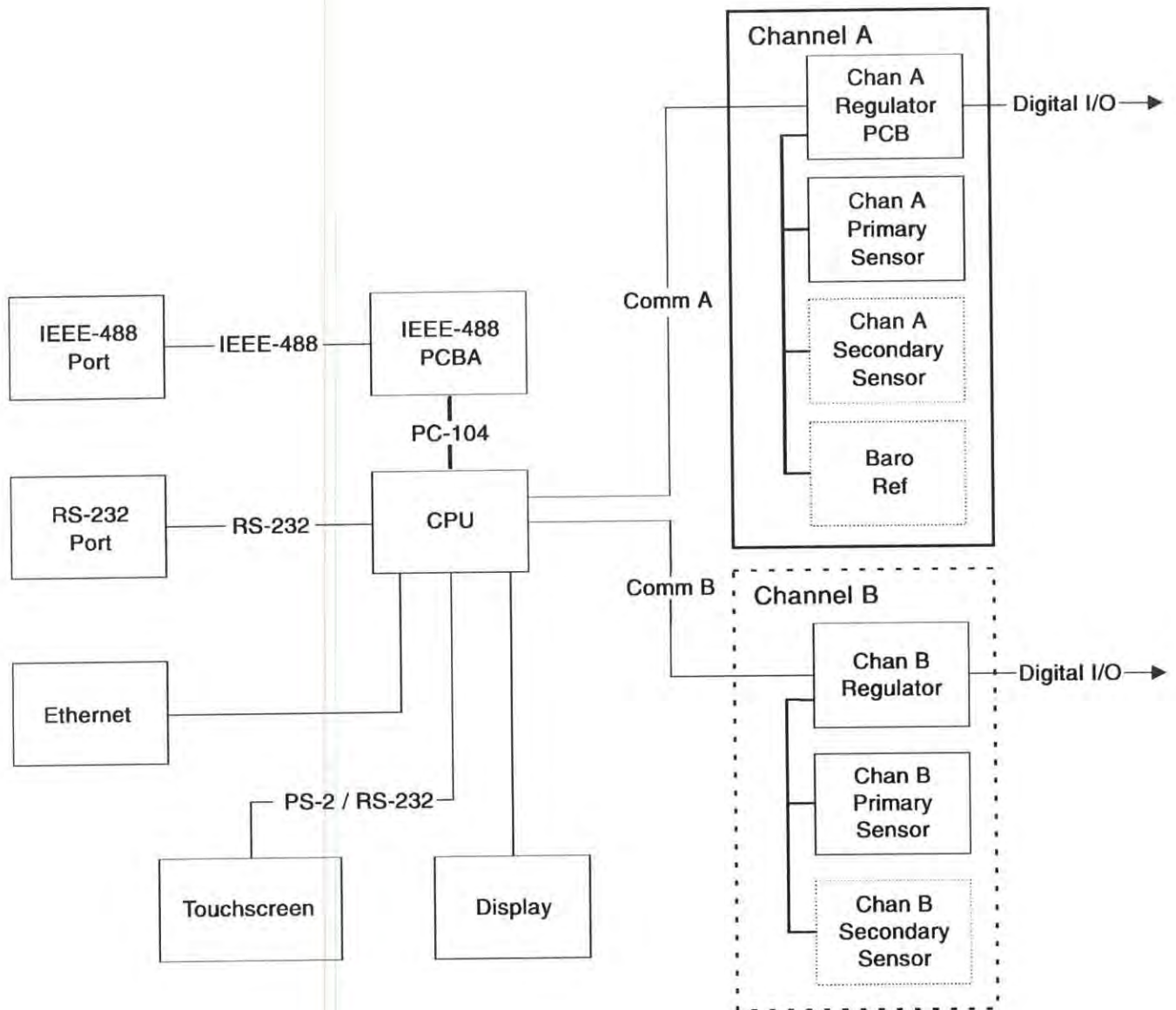

Figure 1.8 - Electrical Block Diagram

POWER UP!

You can confirm that your APC 600 is operational right now. Simply apply power to the power connector on the rear of the instrument, remove any plastic plugs from the rear panel pressure ports and switch the power switch ON. The system will go through a brief initialization process and then a display will appear similar to the operating screen shown in Figure 1.9.

Touch the Mensor Logo on the header bar and a drop-down window will appear as in Figure 1.10, listing the Mensor corporate address and other contact information. Simply touch [Close] at the bottom of the window to close this window.

MENSOR SERVICE PLUS

If you have problems using your APC 600 and you don't find the answer in this manual, contact Mensor at 1.800.984.4200 (USA only), or 1.512.396.4200 for personal assistance, or at any of the on-line addresses listed by touching the Mensor logo on the screen. We are ready to help.

After the Warranty

Mensor's concern with the performance of this instrument is not limited to the warranty period. We provide complete repair, calibration and certification services after the warranty for a nominal fee as explained in Section 5, *Maintenance*.

Calibration Services

In addition to servicing our own products Mensor can perform a complete pressure calibration service, up to 20,000 psi, for all of your pressure instruments. This service includes a Certificate of Compliance and Calibration and a record of traceability to the pressure standards of the United States National Institute of Standards and Technology (NIST).

Accreditation's

Mensor Corporation is registered to ISO 9001:2000. The calibration program at Mensor is accredited by A2LA, as complying with both the ISO/IEC 17025:2005 and the ANSI/NCSL Z540-1-1994 standards.



Figure 1.9 - Typical Operating Screen

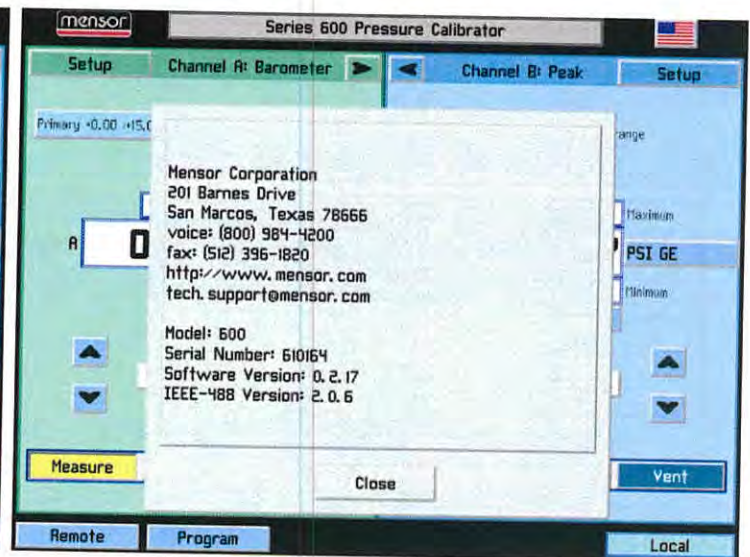
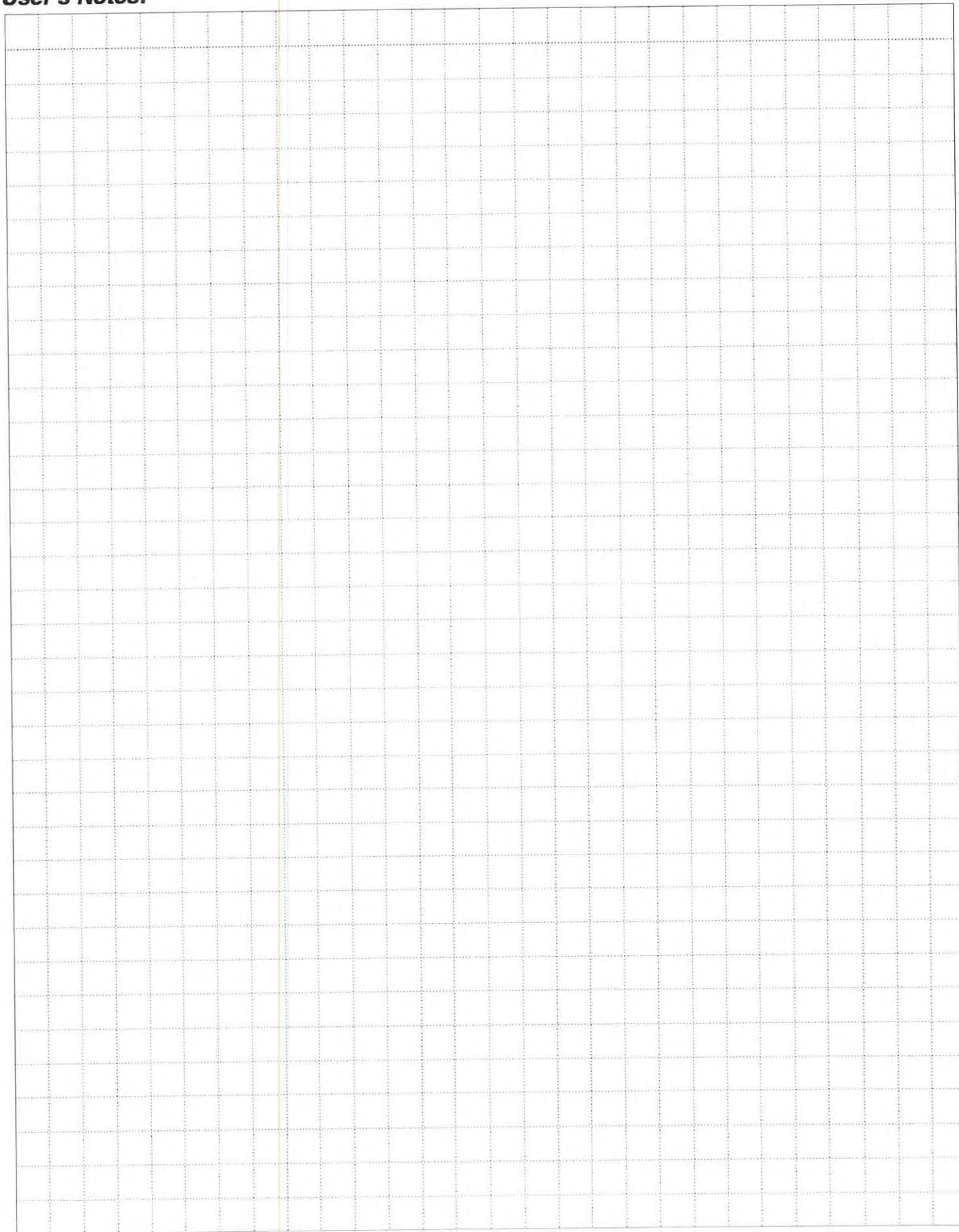

Figure 1.10 - Basic Display Information

User's Notes:



Section 2: INSTALLATION

MOUNTING

The instrument can be set up on a table top or it can be rack-mounted. Rack mount adapters are optional on the APC 600 and require an adapter panel (see 'Rack Mount Kit' in the *Options* section).

The special sensors used in the APC 600 are relatively insensitive to tilt and vibration. However to further assure stability and accuracy, avoid mounting the instrument on surfaces subject to excessive motor or machinery vibration.

PRESSURE CONNECTIONS

NOTE: When making up a connection to an o-ring adapter port use a back-up wrench to prevent over-stressing the threads in the manifold block.

All of the pressure ports on the rear are female 7/16 - 20 SAE/MS straight threads per MS16142 and SAE J514 table 14. They require a tube fitting boss seal with an o-ring per MS33656. Mensor provides female 1/8" NPT adapter fittings with the instrument. The pressure connections can be made to these adapters with the proper mating hardware. We recommend the use of

either Loctite® Hydraulic Sealant or new teflon tape on the threads of any male pipe fitting. Do not use sealant on fittings sealed with an o-ring. The integrity of each seal is particularly important since even microscopic leaks can cause errors in pressure measurements. The rear panel connections and a complete pneumatic schematic, including the optional secondary transducer, are provided in the the *Maintenance* Section (see Figures 5.3 and 5.6). Requirements for connecting to the ports on the APC 600 manifold are as follows:

Supply Port

Connect a source pressure to the SUPPLY port of each channel. See "Source Pressure" in the *Specifications* section for supply pressure requirements for various pressure ranges.



CAUTION: The control channels are completely independent. Separate supply pressures should be applied to the control channels based on the maximum pressure range of each channel. **Applying source pressure higher than the recommended pressure can cause permanent damage to the control channel!**



Figure 2.1 - Rear Panel

NOTE: Performance can be enhanced with a well-regulated source pressure.

Measure/Control Port

Connect a device to be tested to the MEASURE/CONTROL port. In MEASURE mode the APC 600 will precisely measure the pressure at this port up to the full scale range of the active sensor.

A static pressure value or a step value, can be programmed using an on-screen keypad. That pressure will then be output to the MEASURE/CONTROL port by switching to the CONTROL mode of operation.



WARNING: HIGH NOISE LEVELS! As pressure decreases compressed gas will escape out the EXHAUST port. For ranges above 600 psi high noise levels may result during such pressure releases. To overcome objectionable exhaust noise either install a muffler or route the port to a remote location.



CAUTION: Improper use of this equipment may impair protection provided by this instrument.

Exhaust Port

If sub-atmospheric control pressure is required a vacuum pump must be connected to the EXHAUST port. Otherwise, this port may be left open to atmosphere.

Reference Port

On gauge units this port is connected to the reference side of the transducer, and on absolute units it is internally capped. This port is normally left open to atmosphere but may be attached to a snubber assembly on very low pressure instruments.

Remote Bus Connections

See Section 4, *Remote Operation* for connections and commands for operation over the ethernet, RS-232 serial port or IEEE-488.

Digital I/O Connection

The Digital I/O connection consists of four pins:
 Pin 1 - +5 VDC
 Pin 2 - Output of module, pulled up to 5V
 Pin 3 - Input to module, protected by 200 ohm current limiting resistor
 Pin 4 - Ground

(See 'Digital I/O' in the *Specifications* section)

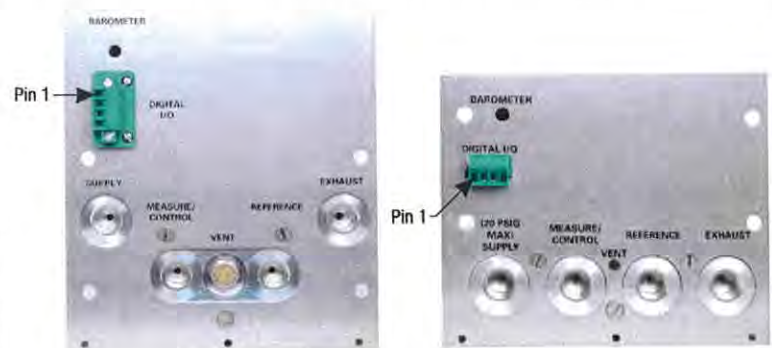

Figure 2.2 - Digital I/O Connection

POWER ON

After the pressure connections are secure, apply power to the power connector on the rear of the instrument and switch the power switch ON. The instrument will go through an initialization process and system check. As soon as the system check is completed the system will default to an operating screen similar to Figure 3.1. Allow at least 15 minutes of warm up before performing critical pressure measurements.



WARNING: EARTH GROUND! Any power adaptors or surge protection devices that negate the protective earth ground should not be used.

The power cord is the disconnection device and its outlet should be accessible and contain a protective earth ground.



WARNING: VENTILATION! Do not block airflow to ventilating fan located on rear of instrument.

Section 3: LOCAL OPERATION

GENERAL

This section describes the procedures for operating the APC 600 from the front panel. Instructions for operating the device remotely from an external computer are covered in the next section, *Remote Operation*. By following the procedures provided in these two sections and Section 6, *Calibration*, you can expect your APC 600 to deliver maximum accuracy and dependability for many years of useful service.

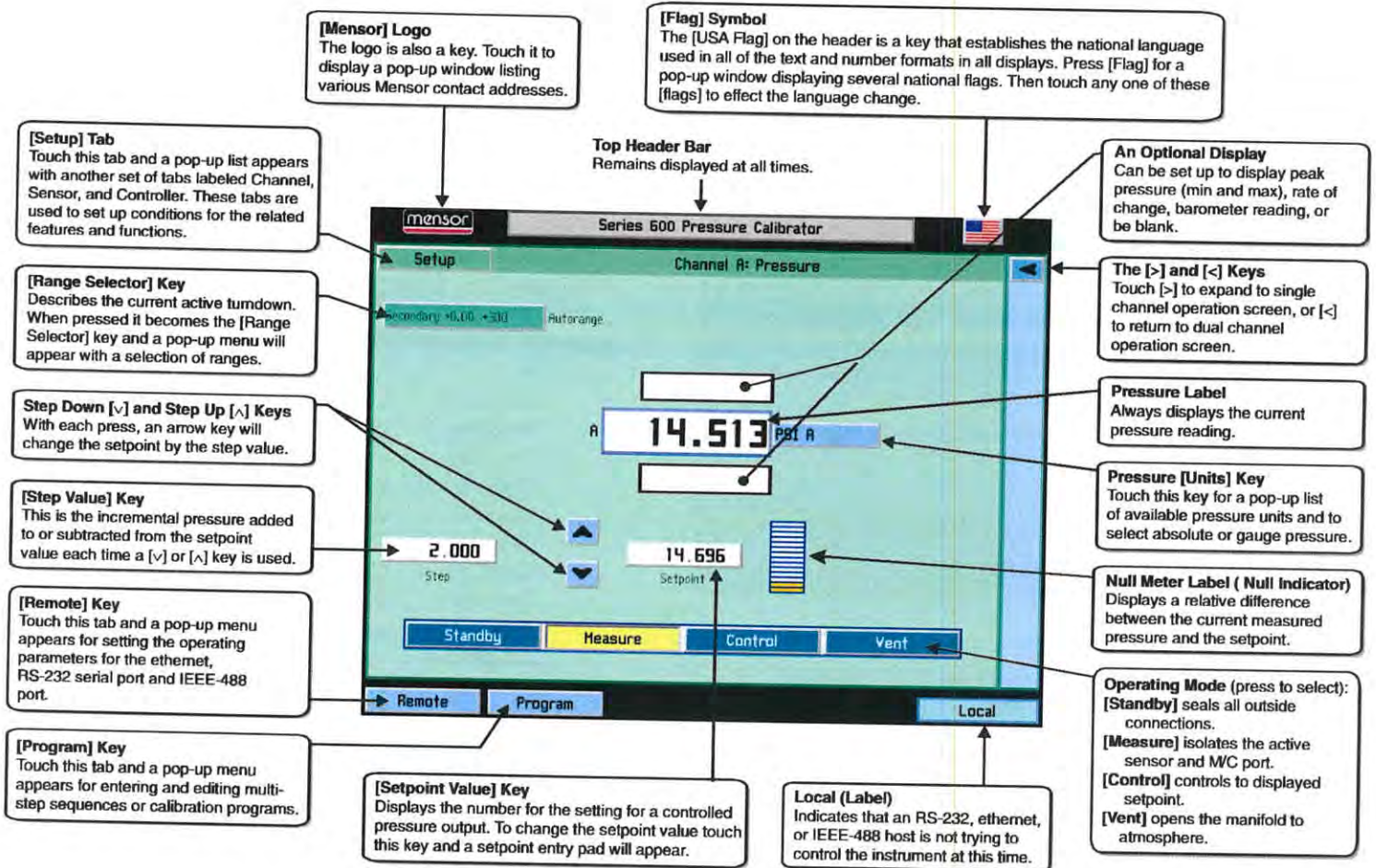

Figure 3.1 - Display Screen Features

KEYS AND TABS

Local operation is accomplished by observing the data presented in the display, then pressing the on-screen [key] or [tab] for the desired function. Throughout this manual characters enclosed inside square brackets [] represent the associated on-screen touch point.

DISPLAY SCREEN FEATURES

Figure 3.1 provides a brief description of the features shown on a single channel display.

Figure 3.2 is an example of a typical display after initialization. To expand the selected channel to a single channel operation screen as shown in Figure 3.1, press the [>] key. The [Standby] key appears on the screen when expanded. To expand or return to a dual channel operation screen press the [<] or [>] key.

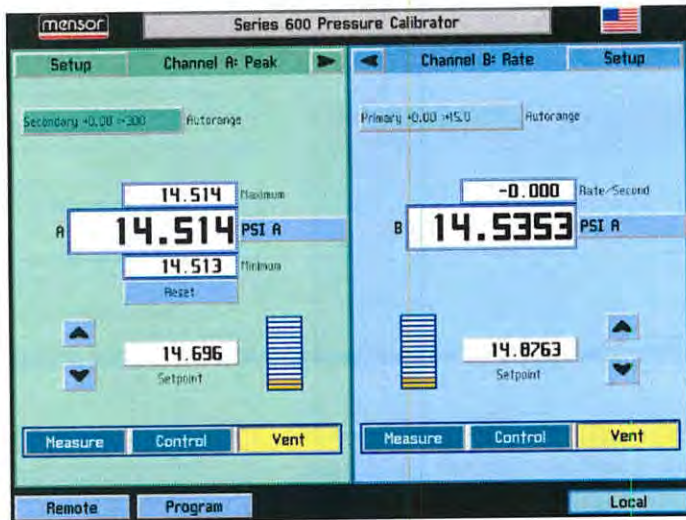

Figure 3.2 - Typical Operation Screen

All of the APC 600 screen features are described in more detail in the rest of this section.

[Mensor] Logo

The logo is also a key. Touch it to display a pop-up window listing various Mensor contact addresses (see Figure 1.10 in the *Introduction* section). Touch [Close] to close the window.



[Flag] Symbol

The [USA Flag] on the header is a key that establishes the national language used in all of the text and number formats in all displays. Press the [Flag] for a pop-up window displaying several national flags (Figure 3.3). Touch any one of these [Flags] to effect the language change.



Figure 3.3 - Language Selection Window

The current language selections available are:

Language	Country
English	USA
German	Germany
German	Switzerland
English	Great Britain
Chinese	China
English	Canada
French	France
French	Switzerland
English	Ireland
Korean	Korea
French	Canada
Italian	Italy
Russian	Russia
Polish	Poland
Japanese	Japan
Spanish	Mexico
Spanish	Spain

NOTE: The language selection acts on the screen displays only, and does NOT affect remote commands and responses. All remote dialogs listed in the *Remote* section are literal as described.

[>] and [<] Keys



The [>] and [<] keys will expand the selected channel to single channel operation screen, or return to dual channel operation screen.

Turndown Label and [Range Selector] Key

The turndown label in the upper left portion of Figure 3.4 describes the current active turndown as Secondary +0.00 :+300. This is the full scale range for one of several turndowns assigned to the secondary transducer. The turndown label becomes the [Range Selector] key. Different colors are used to distinguish primary and secondary Transducer ranges. The currently active range is highlighted with a yellow background. Touch any range other than the yellow one to select a different active turndown as shown in Figure 3.5. The last selection in this range selector is [Autorange], which will automatically switch to the most accurate turndown range in the system capable of measuring the current pressure. Each change is immediately reflected in the turndown label. There is also a label beside the current active turndown to show if you are in range hold or autorange.

NOTE: Some pressure units can cause a number to be too long for the value window. In those cases the value will be abbreviated with an "m" (milli), "k" (kilo), or "M" (mega) multiplier appended to the range in the range drop list.

An important feature of the APC 600 is that transducers can easily be changed. A transducer can be replaced in the APC 600 in less than 30 seconds, with no tools required. Each installed transducer identifies itself to the system using its on-board stored data. Among the items stored in this data are the transducer serial number, curve characterizations and calibrations for each turndown, the dates of calibration, and the transducer's software version.

NOTE: There is no alarm or signal that a transducer has been removed or exchanged. If security is an issue, a visible seal or calibration sticker might be placed on the front panel in such a manner that it must be broken to gain access to the transducers.

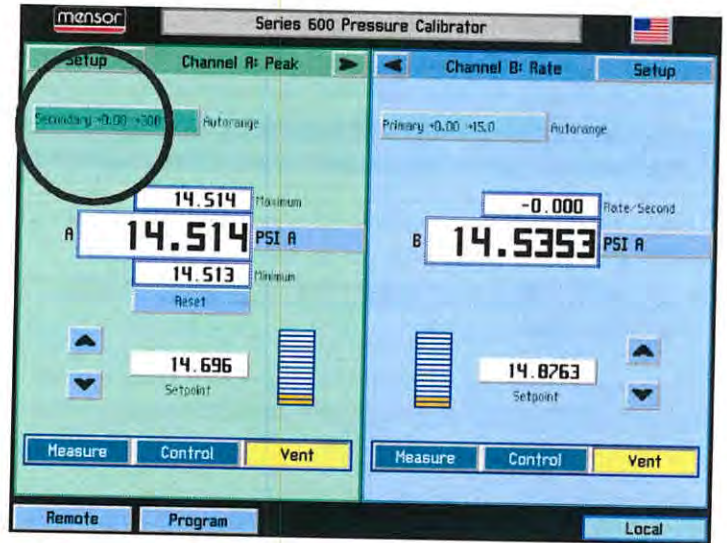

Figure 3.4 - [Range Selector] Key

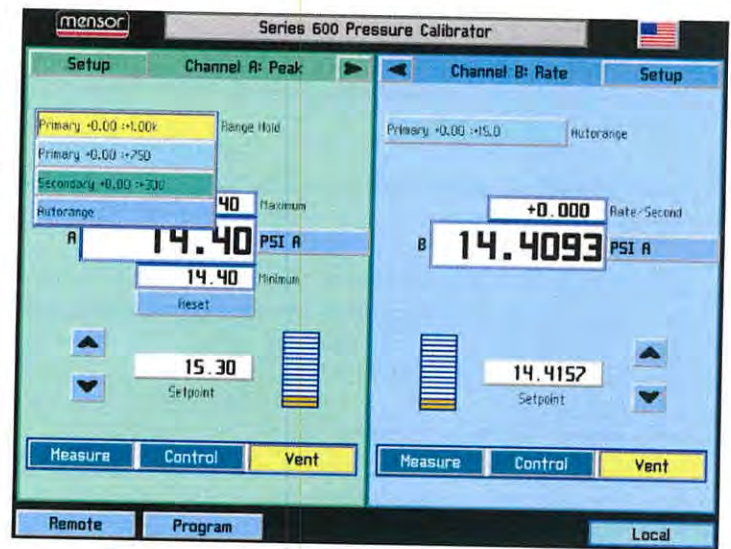

Figure 3.5 - [Range Selector] drop-down Menu

Pressure Label

Below the [Turndown] key shown in Figure 3.4 is a larger label showing the measured pressure value of "14.514". This large label always displays the current pressure reading.

Pressure [Units] Key

To the right of the pressure label is the [Units] key, shown in Figure 3.4 as [PSI]. Touch [PSI] and a pop-up menu of pressure units will appear as in Figure 3.6. This menu includes [User 1] and [User 2] keys allowing the user to enter customized pressure units. Touch [PSI] and it will toggle to Pascal. Press a [Value] key to enter a custom multiplier to equal either one PSI, or one Pascal, whichever is showing in the user multiplier base units key.

The upper right [absolute] or [gauge] key allows emulation mode if an optional barometric sensor is installed. See Section 8, *Options*.

The current units are highlighted by a yellow background. Touch any other [Pressure Units] key, and press [OK] to enable change and return to previous operation screen. All of the displayed pressure values will have changed to correspond to the newly selected units at the correct conversion ratio.

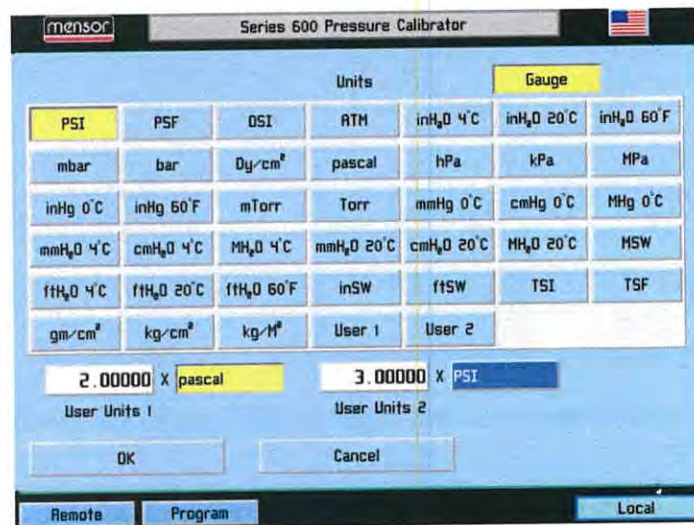

Figure 3.6 - Units Selection Window

[Step Value] Key

On the left side of the screen as seen in Figure 3.1 is the [Step Value] key. The step value displayed is 2.000. This is the incremental pressure added to or subtracted from the setpoint value each time a [V] or [^] key is used on the main screen. To change the step value touch the [Step Value] key and the step entry pad as shown in Figure 3.7 will appear.

This number pad shows the maximum and minimum values applicable to the active turndown. There is also a Current Value and a New Value window. Enter a new step number and then press [OK], or else touch [Cancel] to return to the operate screen without changing the step value. Press CE to backspace.

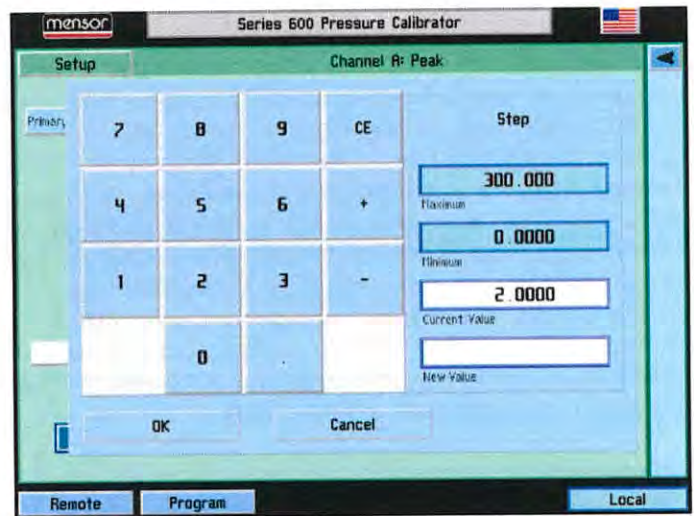

Figure 3.7 - Step Value Window (Single Channel)

Step Down [V] and Step Up [^] Keys

As shown in Figure 3.1, the [V] and [^] keys are located to the side (different for A and B Channels) of the [Setpoint Value] key; one for Step Down [V], and another for Step Up [^]. Pressing an arrow key will change the setpoint by the step value until the control limits of the channel are reached.

Control Pressure [Setpoint Value]

The number displayed inside the [Setpoint Value] key is the setting for a controlled pressure output. When the [Control] key at the bottom of the active channel screen is switched to [On] the regulator will attempt to present that precise pressure to the Measure/Control port on the rear panel. The setpoint number is changed either by using the [V] and [^] keys, or by touching the [Setpoint Value] key to input a new number.

If the displayed number is beyond the range of a selected turndown in range hold mode, the number will change to a control value within the limits of the turndown. The setpoint will change in value automatically, but it will not be restored automatically if the previous turndown is reselected.

[Standby] key: When this key is ON all outside connections are sealed.

[Measure] key: When this key is ON the active sensor and the Measure/Control port are connected and isolated from the rest of the internal pneumatics.

[Control] key: When this key is ON the unit will attempt to control to the setpoint displayed.

[Vent] key: When this key is ON the internal pneumatics are open to atmosphere.

Remote Setup

Refer to 'Remote Setup' in Section 4, *Remote Operation*.

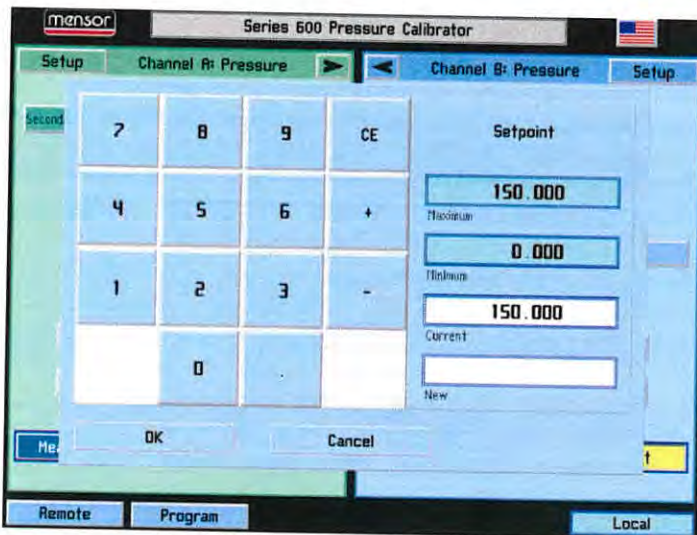

Figure 3.8 - [Setpoint Value] Window

[Program] Key

The [Program] key on the bottom left of the operation screen (Figure 3.2) enters the main program creation/edit screen shown in Figure 3.9. Programmed multi-step sequences can be entered and edited from this screen. There are sample programs available in the instrument that can be edited and renamed. A saved program can be executed by entering the setup channel screen and selecting the [Program] key. The APC 600 can store up to 64 programs with up to 100 steps in each program.

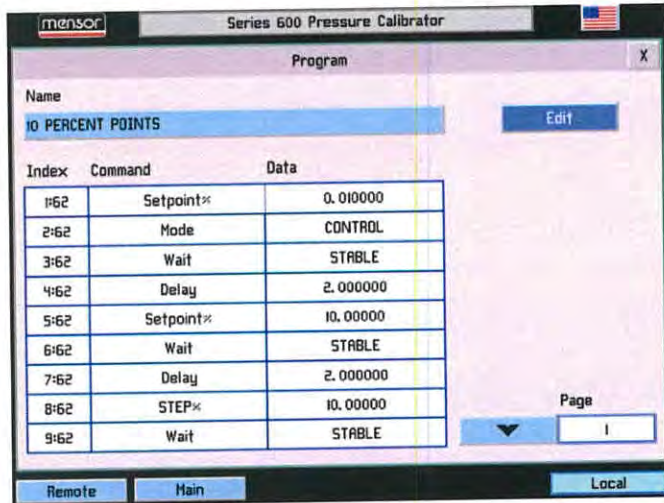

Figure 3.9 - Main Program Screen

The large key at the top of this screen contains the program name of the currently active program that can be run or edited. If this key is pressed, it displays a list of saved programs as shown in Figure 3.10. The up and down arrow keys display additional pages of programs. To select a program to run or edit, simply press the name of the program.

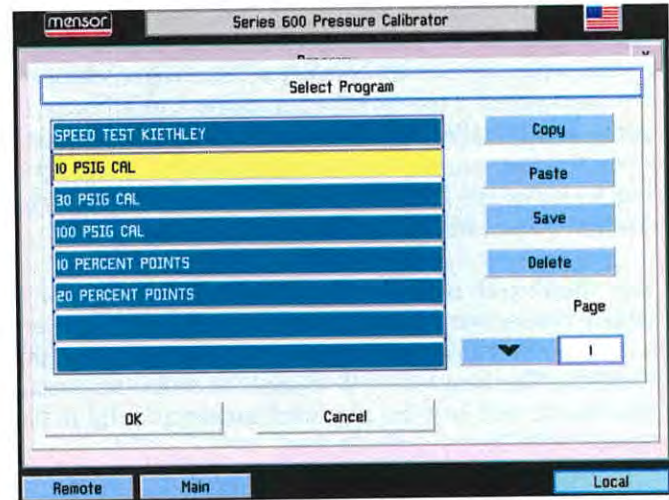

Figure 3.10 - Program Selection Screen

To create a new program sequence, select a blank line and press [OK]. To copy an existing program, select the program to be copied, press [Copy], select a new line (or an existing program to overwrite) and press [Paste]. The [Delete] key erases a program from memory.

Editing or Creating a Program

To edit or create a program, select a program name from the Program Selection Screen and press [OK]. This brings up the main program screen. Below the [Name] key is a table that shows a synopsis of the program steps. There are also up and down arrow keys to display additional pages of program steps.

To edit the selected program press the [Edit] key. This displays the program editing screen shown in Figure 3.11.

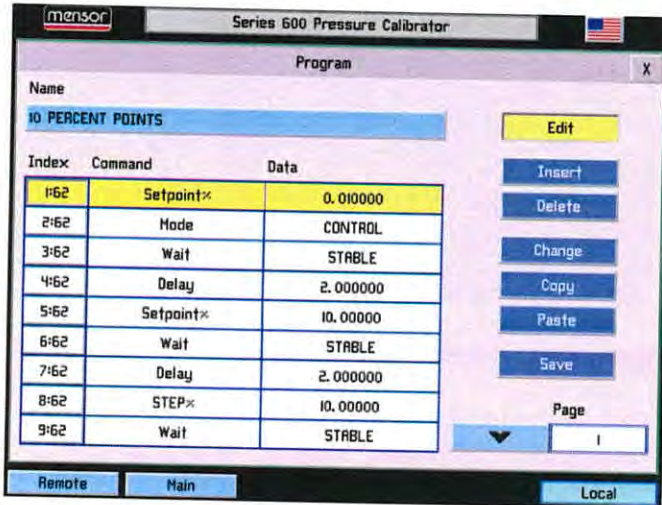

Figure 3.11 - Program Editing Screen

Each program line shown in Figure 3.11 only executes one function or command. Each line has an index number associated with it. For example, if a program has 30 commands, the first command index is 1:30 to represent that it is command one of 30 to be executed.

To edit individual program lines, select the index number of the program line to edit.

The [Insert] key: inserts a new program line before the selected one. This also re-scales the index numbers accordingly.

The [Delete] key: deletes the selected program line and re-scales the index numbers accordingly.

The [Change] key: displays the program line edit screen as shown in Figure 3.13. Its functionality is described in the following text.

The [Copy] key: copies the selected program line.

The [Paste] key: To paste a copied program line over an existing line, select the program line to be overwritten and press the [Paste] key.

The [Save] key: saves the individual program lines to the program and the program to memory. If program lines are edited and the main program screen is exited without pressing the [Save] key, a warning dialog box is displayed prompting the user to save program changes or cancel.

To change the name of the program, press the [Name] key. This displays a keyboard screen shown in Figure 3.12. Enter the name of the program and press [OK] to return to edit the program steps.

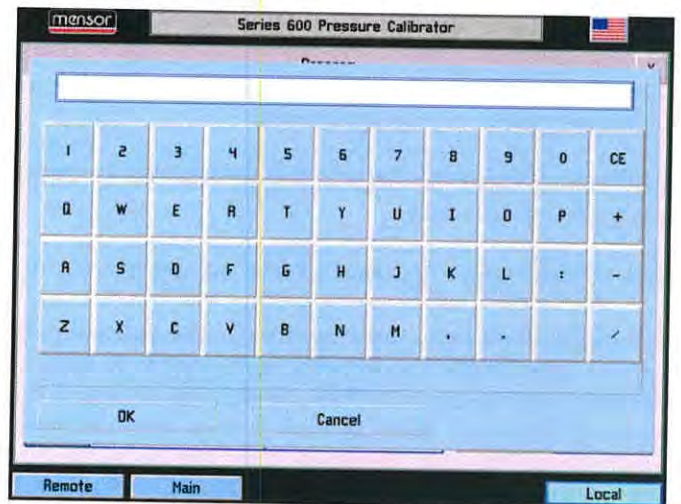

Figure 3.12 - Keyboard Screen

The Program Line Edit Screen (Figure 3.13) sets the function of each program line. Each program line performs the function selected of the ones displayed in the left-most column.

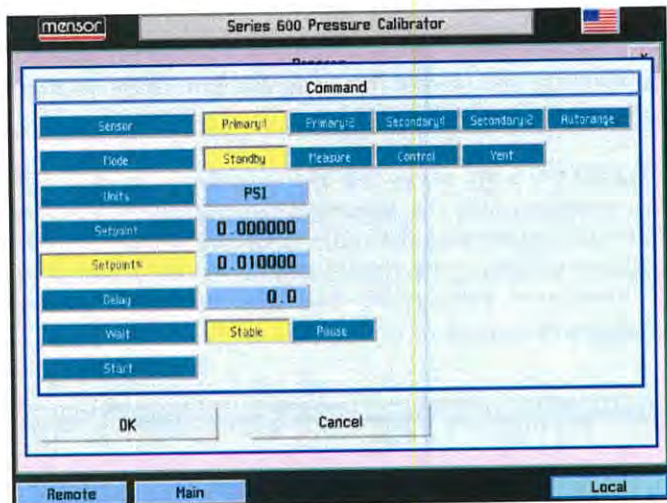

Figure 3.13 - Program Line Edit Screen

The [Sensor] key: This key selects which sensor and turndown to use for the program.

The [Mode] key: The [Mode] key selects the operation mode of the APC 600.

The [Units] key: This key selects the pressure units.

The [Setpoint] key: This key allows the control pressure to be set with the key just to its right. Because of the flexibility of the APC 600, it should be noted that to make the APC 600 control at this setpoint there needs to be another program line that puts the APC 600 into the control mode.

The [Setpoint%] key: The [Setpoint%] key sets the control pressure at the entered percentage of the range of the currently active transducer.

The [Delay] key: The [Delay] key delays the execution of the program for the entered number of seconds.

The [Wait] key: The [Wait] key delays the execution of the program until the instrument measures a stable pressure, or the control pressure stabilizes within the control parameters or pauses until the operator presses a key to continue the program execution.

The [Start] key: The [Start] key causes execution of the program to begin at the first program line. This is useful for running a program repeatedly until the stop key (the key with the black filled box) is pressed by the operator.

Running a Program

To run a stored program, select the program mode from the channel setup screen (see 'Channel Setup' on the following page). The main operation screen looks like Figure 3.14.

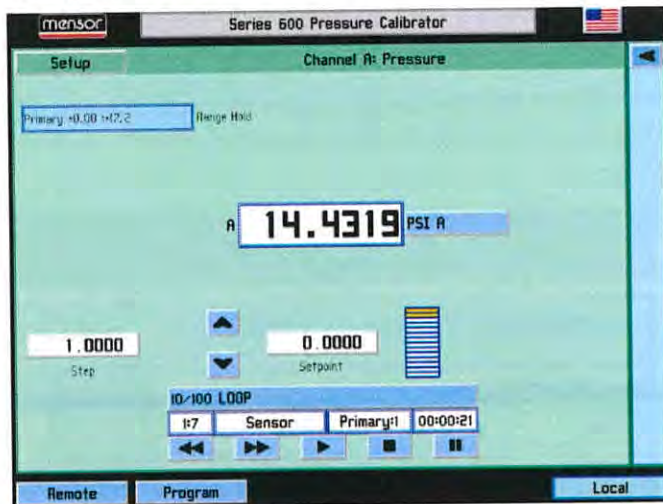

Figure 3.14 - Main Operation Screen in Program Mode

At the bottom of the screen, the function tabs (Measure, Control and Vent) are replaced by information and tabs pertaining to the selected program. The large key at the top of this section is the program name. Any saved program may be selected directly from this screen by pressing this key and selecting the program to run.

When a program has been selected, the line below the program name key shows the current program line that is or will be executed. The rightmost box on this line shows the time at which the program has been on the current program line.

The five keys below this control the operation of the program.

The [\ll] key steps one command line back.

The [\gg] key steps one command line forward.

The [\gt] key begins execution of the program at the first program line. It is also used to re-start a program at the current line after a wait/pause program line.

The next key shows a black square. Pressing this key stops execution of the program and resets the program to the first program line.

The [||] key pauses program execution at the current program line. If the [\gt] key is subsequently pressed, the program begins execution at the next program line.

[Local] Label

On the bottom right of the operation screen (Figure 3.2) is a 'Local' label to indicate that an RS-232, ethernet, or IEEE-488 host is not trying to control the instrument at this time. The text of this label will change to "Serial", the IP address of the controller, or "GPIB" when the APC 600 receives a remote command.

[Setup] Key

Touch the [Setup] tab on the top left or top right corner of the Operation screen (Figure 3.2) and a new display appears with another set of tabs across the top as shown in Figure 3.15. These tabs are labeled [Channel], [Sensor], and [Controller]. The tab and screen that was last accessed is active by default. The top tabs are used to set up conditions for the related feature/function as explained in the following text.

[Channel] Setup

Press the [Channel] tab to access the Channel Setup page as shown in Figure 3.15. From there the user can select the optional display function to be [Pressure], which will show only the current reading, or have it show [Peak], [Rate], or [Barometer] readings.

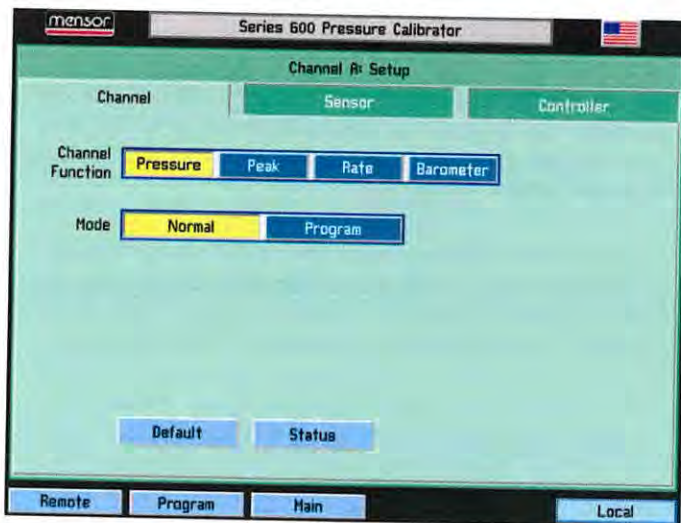

Figure 3.15 - Channel Setup Screen

The content of the three active displays are:

[Pressure]: Shows no alternate readings on the screen, only the measured pressure reading.

[Peak]: Displays the highest and lowest pressure points since the last [Reset], or power up. Figure 3.2 shows an example of the Peak feature displayed in this window.

[Rate]: Reports the rate at which the measured pressure is changing in units/second.

[Barometer]: If this optional feature was ordered with your APC 600, press this key to display the atmospheric pressure reading.

[Normal] (mode selection): This mode will allow the user to command the instrument to individual set-points manually or remotely.

[Program] (mode selection): This mode will allow the user to define and run user entered program sequences (Figure 3.10).

[Default]: Touch this key to immediately reset the instrument to the following conditions:

- Autorange ON; a mid range module defaults to low overshoot mode (see "[Sensor] Setup" on the following page)
- Step value: Ignore if valid; Set to 1 if out of range
- Setpoint: Ignore if valid; Set to 0 if out of range
- Restart peak maximum and peak minimum
- Set sensor filter to Normal
- Set control rate to Maximum
- Set max. allowable control point to match the highest max. turndown in the instrument
- Set minimum allowable control point equal the lowest minimum turndown in the instrument
- Set the stable window to 0.003% FS
- Set the stable delay to 4 seconds.
- Any existing conditions not covered above will be unaffected.

[Status]: Touch this key to display all current channel information including: Model, Software Version, Serial Number, Range, and Units. See Figure 3.16.

Resolution: The Resolution [value] key allows the user to enter the number of significant digits that will be displayed on the operate screen. See Figure 3.18.

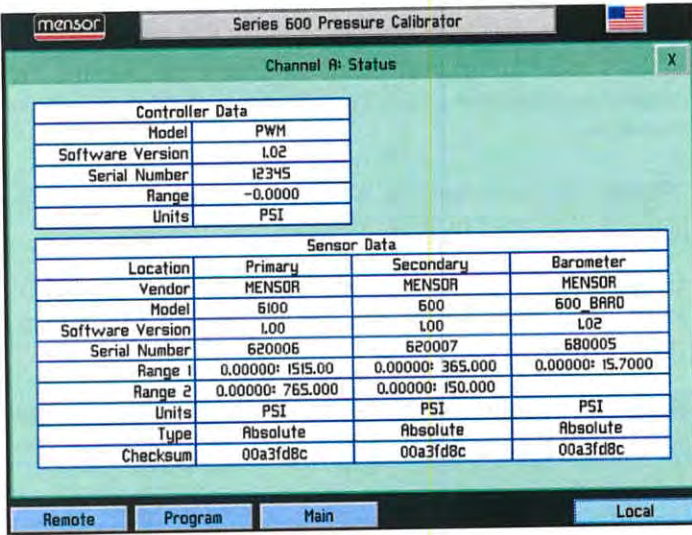

Figure 3.16 - Status Screen

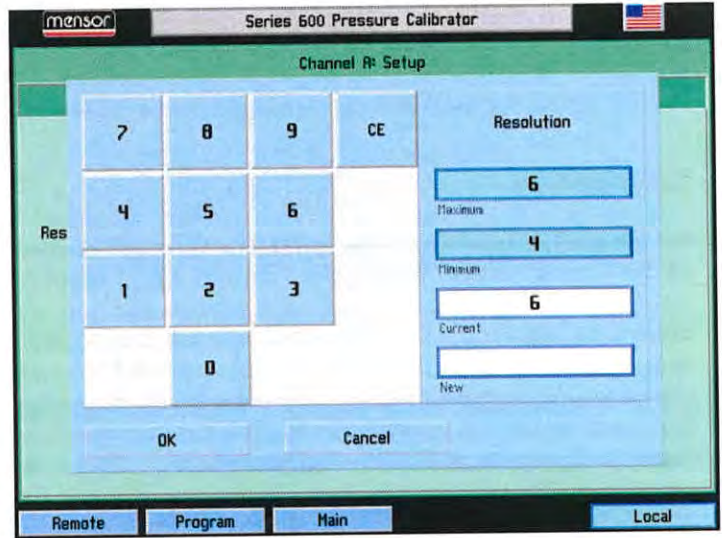

Figure 3.18 - Resolution Window

[Sensor] Setup
Touch the [Sensor] tab and Figure 3.17 will appear.

The [Calibrate] Setup key: Details for the [Calibrate] key are given in Section 6, *Calibration*.

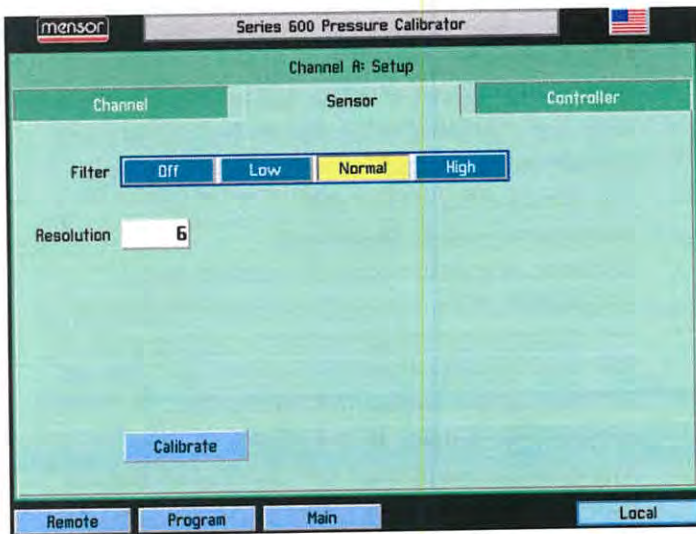

Figure 3.17 - Sensor Setup Screen

[Controller] Setup
The controller setup screen (Figure 3.19 for low range pressure or Figure 3.23 for mid range pressure) is used to set the control parameters for the selected pressure control channel.

The controller test screens are an interactive diagnostic display used for troubleshooting the overall pneumatic system of the APC 600. Proper use of these features are described in Section 5, *Maintenance*.

Filter: The Filter is an electronic filter to smooth out the pressure readings. Because of the differences in resolution, more filtering may display a more stable reading for some pressure units. Select the best filter for the current units. [OFF], [LOW], [NORMAL], [HIGH].

Low Range Pressure Regulator

Control Limits: The control limits cannot be set outside the maximum or minimum ranges of the transducers installed on the active channel. To change a limit touch either of the [Limit Value] keys and enter the new value.

Stable Limits: The stable limit is the percent of span of the active range that the current pressure can deviate from the setpoint and still display a stable flag.

To change the stable limit or stable delay press the appropriate key. The pop-up number pad will show the upper and lower limits for the item being edited.

Stable Delay: The stable delay is the number of seconds that the instrument must remain within the stable window before the stable flag is displayed.

Rate: A rate (slewing speed) which best suits the user's test requirements is selected here. The [Slow] rate will use internal pressure generation without the use of the roughing supply and exhaust valves. Use this mode if no external supply or exhaust pressures are applied to the selected pressure control channel. The [Fast] rate utilizes the roughing supply and exhaust valves.

External Volume: If the autotune is turned on, the external volume of the controlled system is calculated automatically for optimum control performance. If the external volume is known, the user can press the

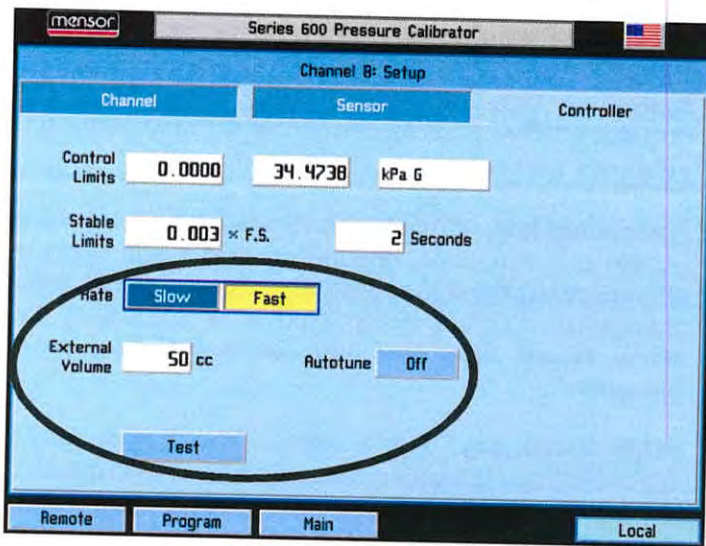

Figure 3.19 - Controller Setup - Low Range Pressure

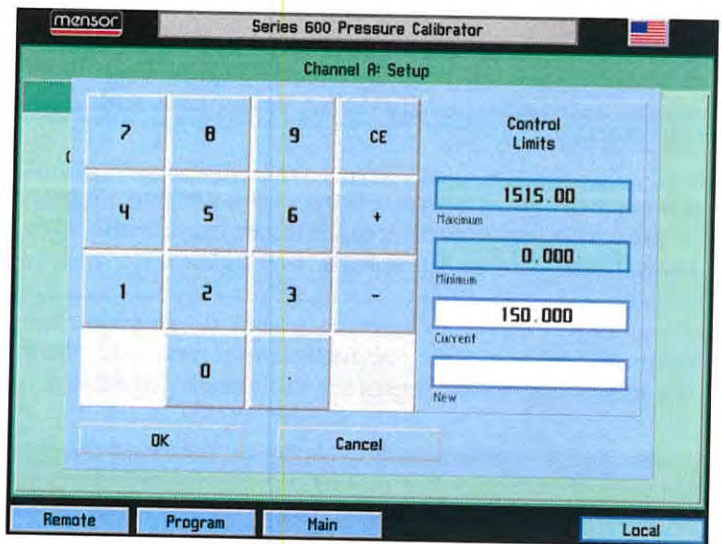

Figure 3.21 - Control Limits Window

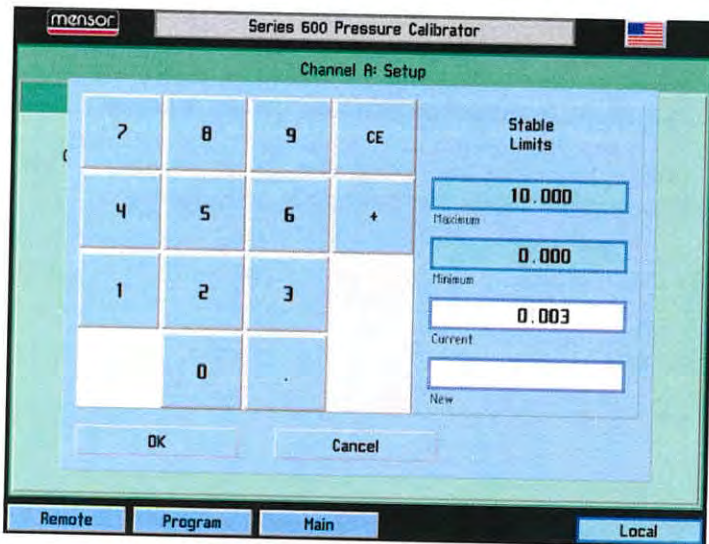

Figure 3.20 - Stable Limit Window

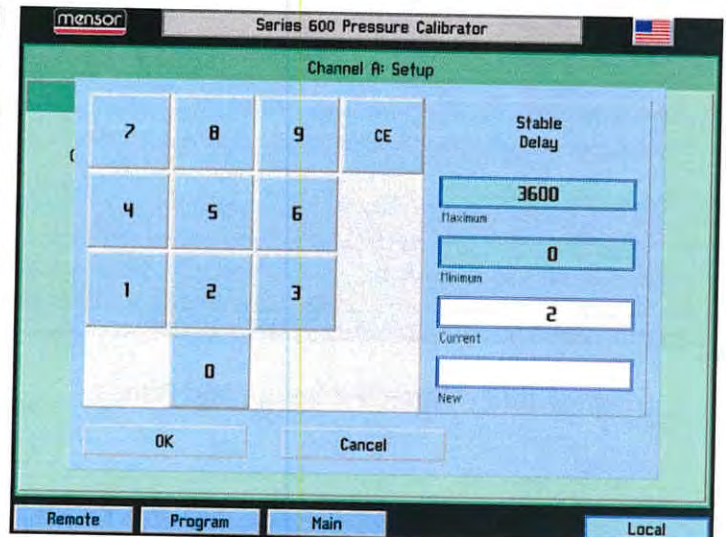

Figure 3.22 - Stable Delay Window

external volume key and enter the volume. Subsequently, if [Autotune] is turned off, the control channel will not re-calculate the external volume on each control setpoint change which will decrease the control times.

Autotune: If the autotune key is turned on, the control channel automatically calculates the external system volume for optimum performance on each control setpoint change.

[Test] key: is used to enter a test mode that gives the user individual control of all solenoids. This is further described in Section 5, *Maintenance*.

Mid Range Pressure Regulator

Control Limits: The control limits cannot be set outside the maximum or minimum ranges of the transducers installed on the active channel. To change a limit touch either of the [Limit Value] keys and enter the new value.

Stable Limits: The stable limit is the percent of span of the active range that the instrument can deviate from the setpoint and still display a stable flag.

To change the stable limit or stable delay press the appropriate key. The pop-up number pad will show the upper and lower limits for the item being edited.

Stable Delay: The stable delay is the number of seconds that the instrument must remain within the stable window before the stable flag is displayed.

Rate: A rate (slewing speed) which best suits the user's test requirements is selected here. The rates vary the pressure slew rate while driving to a pressure setpoint. The [Slow] rate will target approximately .1% of the highest installed range/second. The [Medium] rate will target approximately 1% of the highest installed range/second. The [Fast] rate will target approximately 10% of the highest installed range/second.

Variable rate allows the customer to enter the desired rate in current units/second.

Low Overshoot check: If this is checked, the control channel will minimize pressure overshoot when driving to a new control setpoint.

Reference Vacuum check: ONLY AVAILABLE ON GAUGE UNITS! If checked, customers may pump the reference port to achieve absolute emulation.

[Precision] key: If this key is selected, parameters are loaded into the active channel so that it will operate with minimum overshoot and maximum stability. This changes the control stable window to 0.003% of the active sensor turndown and the stable delay to 4 seconds.

[High Speed] key: If this key is selected, parameters are loaded into the active channel so that it will operate in a high control speed mode. This changes the control stable window to 0.006% of the active sensor turndown and the stable delay to 1 second. It also changes the way the controlled pressure approaches the setpoint to minimize the time to stable.

[Test] key: This key is used to enter a test mode that gives the user individual control of all solenoids. This is further described in Section 5, *Maintenance*.

[Tune] key: This key is used to tune the regulator. This is described further in Section 5, *Maintenance*.

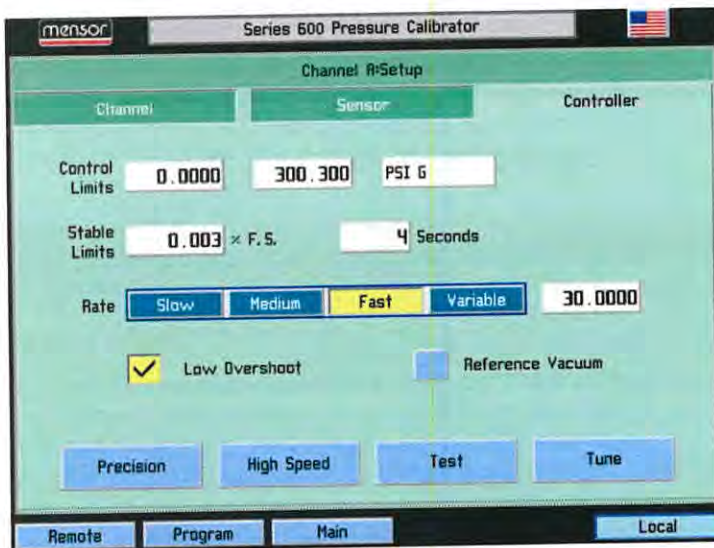

Figure 3.23 - Controller Setup, Mid Range

Section 4: REMOTE OPERATION

REMOTE SETUP

Use the following screens to set the operating parameters for the Ethernet, RS-232 serial port, and IEEE-488.

[Remote] key: Press the [Remote] key located on the bottom left corner of the screen, and a new display appears with another set of tabs across the top as shown in Figure 4.1.

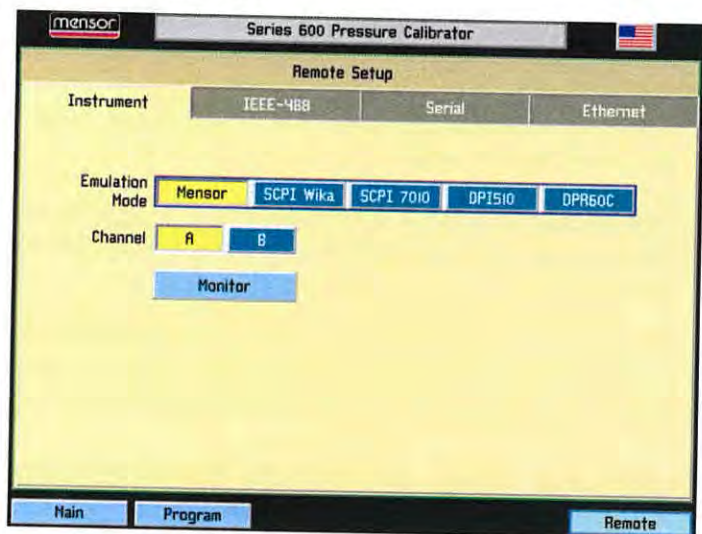

Figure 4.1 - [Remote] Key

[Instrument] key: Press the [Instrument] tab to set up available emulation modes. The default command set is Mensor.

[A] [B] (channel selection): This channel selection sets the active remote channel to A or B and is useful for customers using an APC 600 to replace two single channel controllers. The user can simply select the channel here first, then begin their normal program.

[Monitor] key: Press the [Monitor] key to bring up a new screen which displays current remote activity and displays syntax errors. This is helpful when troubleshooting programs.

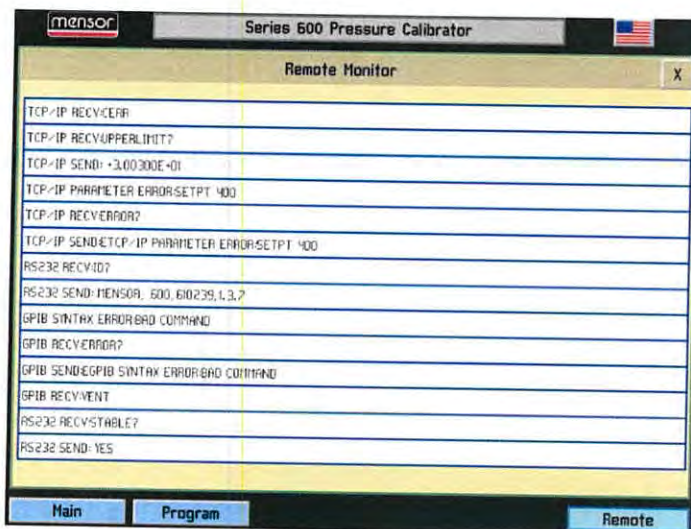

Figure 4.2 - [Instrument] Key

[IEEE-488] key: Press the [IEEE-488] tab to set up the IEEE address. Press the white box and a number keypad will appear for you to enter your new IEEE address and then press [OK].



Figure 4.3 - [IEEE-488] Key

[Serial] key: Press the [Serial] tab to set up the serial port parameters. These parameters should be set up to match your host computer. Default settings are: 57600, 8, 1, none parity, and no echo.

If the Echo checkbox is checked, the APC 600 will immediately echo back characters sent over the serial port.

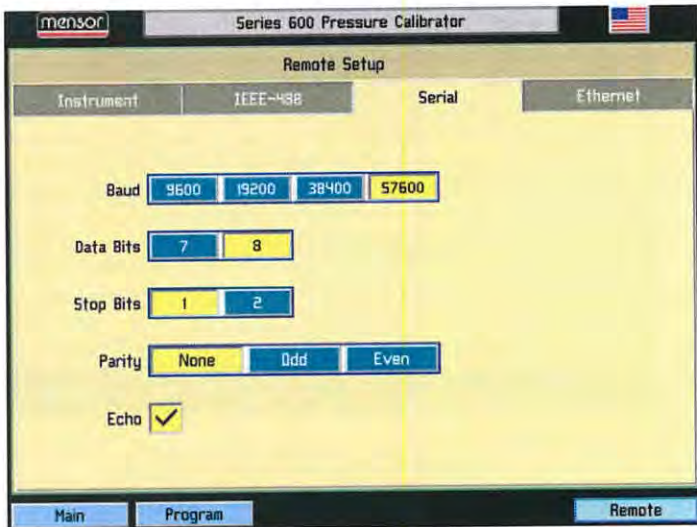

Figure 4.4 - [Serial] Key

[Ethernet] key: Press the [Ethernet] tab to set up the Ethernet parameters. These parameters should be set up to match your host computer.

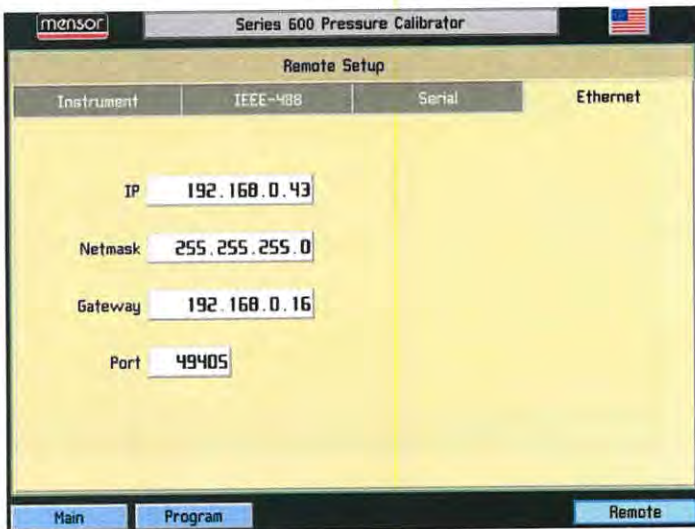



Figure 4.5 - [Ethernet] Key

When the correct values have been selected for all four parameters simply touch any of the keys across the top or the bottom of the screen or the [X] key on the upper right of the window to move on to another function.

Emulation modes are also available for legacy instrument replacement. Contact Mensor for availability.

ETHERNET COMMUNICATION

The ethernet communication port allows the APC 600 to communicate with computers using 10/100Based-T specifications.



CAUTION: Please consult your Computer Resources Department prior to connecting this instrument to your network to verify there are no conflicts with existing IP addresses.

Ethernet communications are transmitted over a standard RJ-45 cable.

Connecting directly to a PC requires a crossover ethernet cable. Hub connection requires a straight ethernet cable.

Prior to first time use of ethernet communication, the four parameters, IP, Netmask, Gateway, and Port must be setup. These are set up in the Remote setup screen.

IEEE-488 (GPIB)

The manufacturer of the host IEEE-488 interface board provides software to allow communication between the board and various programming languages. An interactive program for debugging is usually provided as well. Refer to the board manufacturer's documentation for more information.

Capability Codes

- SH1 Full source handshake capability
- AH1 Full acceptor handshake capability
- T6 Talker with serial poll and unaddress if MLA
- L4 Listener with unaddress if MTA
- SR1 Full service request capability
- RL1 Full remote/local capability including LLO
- PPO No parallel poll capability
- DC1 Full device clear capability
- DT1 Full device trigger capability
- C0 No controller capability
- E2 Tri-state outputs

Interface Functions

The APC 600 responds to the following IEEE-488 interface functions:

- SRQ** Service Request: A service request is asserted whenever an error is encountered. When the bus controller issues a serial poll the error will be cleared. If the host IEEE board includes automatic serial polling capability, turn this feature off in order to view all errors (see ER-ROR? command).
- LLO** Local Lockout: The front panel keyboard of the APC 600 may be locked by sending LLO or the command LOCK ON.
- GET** Group Execute Trigger: When this message is received, the APC 600 will save the current readings until the next time it is addressed as a talker.
- GTL** Go To Local: A GTL message will cause the APC 600 return to local operation and unlock the keyboard.
- DCL** Device Clear: When this message is received, the APC 600 will clear all errors and buffers and remain in the REMOTE mode.
- SDC** Selected Device Clear: The effect is the same as DCL.
- EOI** End or Identify: May be used as a command or query terminator in the place of, or concurrent with, a terminating linefeed.

RS-232 SERIAL COMMUNICATION

The serial communication port allows the APC 600 to communicate in RS-232 format with computers, terminals, PDAs, or similar hosts.

Cable Requirements

RS-232 communications are transmitted over a three conductor, shielded cable terminated in a standard DB9S connector on the instrument end, and usually the same connector on the host end. Figure 4.6 illustrates the proper pin-outs. Notice that each pin 2 is connected to pin 3 on the opposite

end. This configuration is commonly referred to as a 9-pin null modem cable.

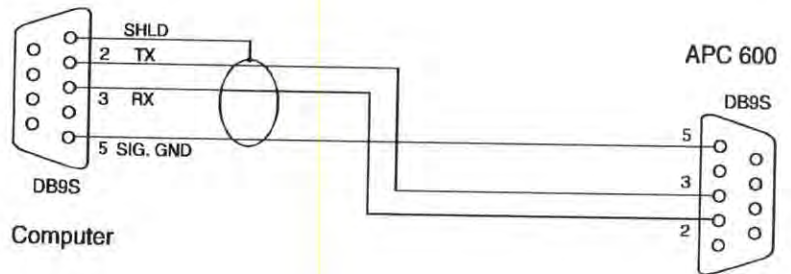

Figure 4.6 - Serial Cable

Command/Query Format

Commands must be sent in ASCII format and terminated with either a carriage return (<cr>), linefeed (<lf>) or both. Commands are not case sensitive. Each query returns a response. If an error is detected the response will include an error flag.

One of the first commands issued when starting remote communications should be "Keylock Yes". This will disable the on-screen keys and tabs, and place the "Keylock" label on the screen. Turning keylock on prevents the potential conflicts that could occur if someone pressed an on-screen key, either intentionally or by accident.

Command/Query Field: Unless otherwise specified, commands are typically converted to queries by appending a question mark to the command. Table 4.1 lists all of the APC 600 command/query keywords.

Data Field: The data field is either in ASCII {string} or numeric {value} form. In the case of multiple data fields, commas are required to separate the fields. Queries do not have a data field. String (text) or value (numeric) data are acceptable in any of the following formats:

Examples of {string} data:

- ON
- OFF
- mBar
- inHg

Examples of {value} data:

- 1
- 1.0
- 5.678
- 25.68324e-5

Command Set Definitions

In this manual a data entry made up of alpha characters is defined as a string, as opposed to data containing only numbers, such as "Enter 1 for ON or 0 for OFF" where 1 and 0 are defined as values.

Command: Any command or query listed in Table 4.1.

Separator: Space (SP). Exception: 0x0a, (LF), which is used to terminate each command.

Data: ASCII representations of numbers, {*value*}, or alpha characters, {*string*}, data as defined above. When sending code a literal variable replaces the braces and the enclosed character(s) shown in the following examples.

Termination: Linefeed (LF) or carriage return (CR) is used to signal the end of a command statement. For IEEE-488 operation "EOI" is an acceptable alternative.

Always send commands in one of the following formats:

1. [Command] [Termination];
2. [Command] [Separator] [Data] [Termination];
3. Queries are special instructions in the form: [Command?][Termination] where the question mark, "?", immediately precedes the terminator.

When a valid query is received, the APC 600 will return {*data*} terminated by CR and LF.

Floating point data is returned in the current engineering units in exponential format.

Output Formats

Pressure readings are returned in exponential notation in a format according to the **OUTFORM** command as follows:

1. <sp> pressure value <cr><lf>
2. <sp> pressure, units number, mode <cr><lf>
3. <sp> pressure, pressure rate <cr><lf>
4. <sp> pressure, minimum peak, maximum peak<cr><lf>
5. <sp> pressure, active sensor (P or S), active turndown (1-4)<cr><lf>
6. <sp> pressure, control point, "stable" or "slewing"<cr><lf>
7. <sp> pressure, "no barometer" or baro reading<cr><lf>

For commands that take boolean data the following strings are acceptable:

0	1
False	True
No	Yes
Off	On

Command/Query List

Table 4.1 on the following page lists all of the current APC 600 specific commands and queries.

NOTE: Channel specific commands are sent to only the active channel. See 'CHAN' command.

Optional emulation modes are available in which an APC 600 can emulate remote functions of different brands of pressure controllers. Please contact Mensor for more details.

Table 4.1 - APC 600 Commands and Queries

Ref	Command	Data	Function/Response
1	?	See "Output Format" text	Returns data per the current output format.
2	Acquire?	{15 char string} Returns: <sp>(YES or NO),{string}<cr><lf>	This command is used when multiple computers would like to control the instrument. Yes if acquisition is successful, No if instrument is being controlled with another computer. The string is an identifier for the controlling computer. See: Release? and Unlock.
3	Address	{1 to 30}	Sets the GPIB Address.
4	Address?	<sp>{value}<cr><lf>	Returns the GPIB Address within 1 to 30.
5	A?	<sp>{value}<cr><lf>	Returns the A channel pressure reading.
6	AR?	<sp>{value}<cr><lf>	Returns the A channel rate.
7	ARS?	<sp>{YES or NO}<cr><lf>	Returns the A channel rate stable flag.
8	AS?	<sp>{YES or NO}<cr><lf>	Returns the A channel stable flag.
9	Autorange	{ON or OFF}	Toggles autorange function to its opposite state, either ON or OFF (enabled or disabled).
10	Autorange?	<sp>{ON or OFF}<cr><lf>	Returns whether the autorange function is enabled or disabled.
11	Autozero	none	Re-zero all ranges that can measure the vented pressure. These adjustments are not password protected and are not saved through power cycles. This command takes approximately 60 seconds.
12	Autozero?	S,T,X,X	Returns autozero data. Where: S= the zero state, 0= complete; T= the estimated remaining time to complete; X = not used at this time (0).
13	Autozeroabort	none	Aborts autozero.
14	Baro?	<sp>{value}<cr><lf>	Returns reading from barometric sensor.
15	B?	<sp>{value}<cr><lf>	Returns the B channel pressure reading.
16	BR?	<sp>{value}<cr><lf>	Returns the B channel rate.
17	BRS?	<sp>{YES or NO}<cr><lf>	Returns the B channel rate stable flag.
18	BS?	<sp>{YES or NO}<cr><lf>	Returns the B channel stable flag.
19	Caldisable	{YES or NO}	Disables the zero and span commands (default = YES). When the caldisable is YES, the zero and span commands are disabled.
20	Caldisable?	<sp>{YES or NO}<cr><lf>	Returns whether or not calibration of the active sensor is disabled.
21	Cerr	none	Clears the error queue.
22	Chan	{A or B}	Sets the active channel on the instrument.
23	Chan?	<sp>{A or B}<cr><lf>	Returns which channel is active.
24	Chanfunc	<sp>{Press,peak,rate,baro}<cr><lf>	Sets the alternate function mode of the active channel.
25	Chanfunc?	<sp>{string}<cr><lf>	Returns the alternate function mode of the channel.
26	Control	none	Instrument placed in Control mode.
27	Control?	<sp>{YES or NO}<cr><lf>	Returns YES if active channel is in Control mode; NO if otherwise.
28	Crate	{Slow, Medium, Fast, Variable} for mid or high range regulator, {Slow or Fast} for low range reg.	Sets the control slew rate for the current channel. For Variable rate see: Rsetpt command.
29	Crate?	<sp>{string}<cr><lf>	Returns the current rate - value corresponds to the parameters for the CRATE command.
30	Decpt	<sp>{4, 5 or 6}<cr><lf>	Sets the number of significant digits displayed.
31	Decpt?	<sp>{value}<cr><lf>	Returns the number of significant digits displayed for the active channel.
32	Default	none	Sets the default values. This command takes approximately 20 seconds.
33	DIO	{0 or 2}	0 turns the digital IO output pin off or low. 2 turns the digital IO output pin on or high.
34	DIO?	{value}	0 if input is low and output is low. 1 if input is high and output is low. 2 if input is low and output is high. 3 if input is high and output is high.

Continued on next page...

Table 4.1 - Continued

Ref	Command	Data	Function/Response																																																						
35	DOC	<mm/dd/yyyy>	Sets the date of cal for the active sensor and turndown.																																																						
36	DOC?	<sp>{mm/dd/yy}<cr><lf>	Returns the date of cal for the active sensor and turndown.																																																						
37	DOM?	<sp>{mm/dd/yyyy}<cr><lf>	Returns the date of manufacture.																																																						
38	Error?	<sp>{string}<cr><lf>	Returns a description of an error.																																																						
39	Errorno?	<sp>{string}<cr><lf>	Returns APC 600 error code and text.																																																						
40	Filter	{Off, Low, Normal, High}	Sets the reading filter.																																																						
41	Filter?	<sp>{string}<cr><lf>	Returns the reading filter.																																																						
42	Gasdensity	{value}	Sets the head pressure gas density in lb/ft ³ .																																																						
43	Gasdensity?	<sp>{value}<cr><lf>	Returns the head pressure gas density in lb/ft ³ .																																																						
44	Gastemp	{value}	Sets the head pressure gas temperature in °F.																																																						
45	Gastemp?	<sp>{value}<cr><lf>	Returns the head pressure gas temperature.																																																						
46	Gateway	{string e.g. nnn.nnn.nnn.nnn}	Sets the Ethernet gateway address.																																																						
47	Gateway?	<sp>{string}<cr><lf>	Returns the Ethernet gateway address.																																																						
48	Height	{value}	Sets the head pressure height in inches.																																																						
49	Height?	<sp>{value}<cr><lf>	Returns the head pressure height.																																																						
50	Highspeed	{Yes or No}	Sets the active channel to high speed mode: .006% stablewindow and 1 second stabledelay.																																																						
51	ID?	<sp>MENSOR,600, {ssssss},{v.vv}<cr><lf>	Returns the instrument identity where {ssssss} is the serial number, and {v.vv} is the software version number.																																																						
52	IP	{string e.g. nnn.nnn.nnn.nnn}	Sets the IP address of the instrument.																																																						
53	IP?	<sp>{string}<cr><lf>	Returns the IP address of the instrument.																																																						
54	Keylock	{Yes or No}	YES to lock, or NO to unlock the on-screen keys.																																																						
55	Keylock?	<sp>{Yes or No}<cr><lf>	Returns current keylock status as YES or NO.																																																						
56	List?	<sp>Pri,X,X;Sec,X,X;Bar,1 <cr><lf>	Returns list of available turndowns on installed sensors in the active channel. X will be non-existent if the turndown is not available.																																																						
57	Listcal?	<sp>PRI,{sn},{td},{mm/dd/yyyy}, {td},{mm/dd/yyyy};SEC,{td},{mm/ /dd/yyyy},{td},{mm/dd/yyyy}<cr> <lf>	Returns the serial number of each installed transducer and calibration dates for each range.																																																						
58	Listrange?	<sp>PRI,{td},{min},{max},{td},{m in},{max};SEC,{td},{min},{max},{t d},{min},{max}<cr><lf>	Returns the minimum and maximum ranges of all installed sensors for the active channel.																																																						
59	Locale	{locale code}	Sets language and Country code: <table border="1"> <thead> <tr> <th>Locale Code</th> <th>Language</th> <th>Country</th> </tr> </thead> <tbody> <tr><td>en_us</td><td>english</td><td>usa</td></tr> <tr><td>en_ca</td><td>english</td><td>canada</td></tr> <tr><td>en_gb</td><td>english</td><td>great britain</td></tr> <tr><td>fr_fr</td><td>french</td><td>france</td></tr> <tr><td>fr_ca</td><td>french</td><td>canada</td></tr> <tr><td>es_es</td><td>spanish</td><td>spain</td></tr> <tr><td>es_mx</td><td>spanish</td><td>mexico</td></tr> <tr><td>de_de</td><td>german</td><td>germany</td></tr> <tr><td>it_it</td><td>italian</td><td>italy</td></tr> <tr><td>zh_cn</td><td>chinese</td><td>china</td></tr> <tr><td>ko_ko</td><td>korean</td><td>korea</td></tr> <tr><td>ru_ru</td><td>russian</td><td>russia</td></tr> <tr><td>de_ch</td><td>german</td><td>switzerland</td></tr> <tr><td>fr_ch</td><td>french</td><td>switzerland</td></tr> <tr><td>en_ie</td><td>english</td><td>ireland</td></tr> <tr><td>ja_jp</td><td>japanese</td><td>japan</td></tr> <tr><td>pl_pl</td><td>polish</td><td>poland</td></tr> </tbody> </table>	Locale Code	Language	Country	en_us	english	usa	en_ca	english	canada	en_gb	english	great britain	fr_fr	french	france	fr_ca	french	canada	es_es	spanish	spain	es_mx	spanish	mexico	de_de	german	germany	it_it	italian	italy	zh_cn	chinese	china	ko_ko	korean	korea	ru_ru	russian	russia	de_ch	german	switzerland	fr_ch	french	switzerland	en_ie	english	ireland	ja_jp	japanese	japan	pl_pl	polish	poland
Locale Code	Language	Country																																																							
en_us	english	usa																																																							
en_ca	english	canada																																																							
en_gb	english	great britain																																																							
fr_fr	french	france																																																							
fr_ca	french	canada																																																							
es_es	spanish	spain																																																							
es_mx	spanish	mexico																																																							
de_de	german	germany																																																							
it_it	italian	italy																																																							
zh_cn	chinese	china																																																							
ko_ko	korean	korea																																																							
ru_ru	russian	russia																																																							
de_ch	german	switzerland																																																							
fr_ch	french	switzerland																																																							
en_ie	english	ireland																																																							
ja_jp	japanese	japan																																																							
pl_pl	polish	poland																																																							

Continued on next page...

Table 4.1 - Continued

Ref	Command	Data	Function/Response
60	Locale?	<sp>{string}<cr><lf>	Returns current language and Country locale.
61	Localgravity	{value}	Sets the acceleration of gravity in feet/sec ² .
62	Localgravity?	<sp>{value}<cr><lf>	Returns the local gravity in feet/sec ² .
63	LowerLimit	Value inside primary transducer range on turndown #1 in current units.	Sets the lower control limit for the active channel.
64	LowerLimit?	<sp>{value}<cr><lf>	Returns the lower control limit for the active channel.
65	Lowovershoot	{Yes or No}	Sets the active channel to low overshoot mode.
66	Lowovershoot?	<sp>{Yes or No}<cr><lf>	Returns the current setting of the lowovershoot mode.
67	Measure	none	Instrument placed in Measure mode.
68	Measure?	<sp>{Yes or No}<cr><lf>	Returns YES if active channel is in Measure mode; NO if otherwise.
69	Mode	{Standby, measure, control, vent}	Sets the operation mode of the active channel.
70	Mode?	<sp>{string}<cr><lf>	Returns the operation mode of the active channel.
71	Netmask	{nnn.nnn.nnn.nnn}	Sets the Ethernet network mask.
72	Netmask?	<sp>{nnn.nnn.nnn.nnn}<cr><lf>	Returns the Ethernet network mask.
73	Outform	{1 to 8}	Sets the output format. See 'Output Formats' in Section 4, <i>Remote Operation</i> .
74	Outform?	<sp>{X}<cr><lf>	Returns the current output format.
75	Peakmax?	<sp>{value}<cr><lf>	Returns the maximum pressure since peakreset was sent.
76	Peakmin?	<sp>{value}<cr><lf>	Returns the minimum pressure since peakreset was sent.
77	Peakreset	none	Resets the peak values.
78	Port	{value}	Sets the Ethernet port of the instrument.
79	Port?	<sp>{value}<cr><lf>	Returns the Ethernet port of the instrument.
80	Precision	none	Sets the active channel to the precision mode: .003% stablewindow and 4 second stabledelay.
81	Ptype	{Absolute or Gauge or A or G}	Sets the instrument pressure type – non-native type only works if the optional barometric sensor is installed.
82	Ptype?	<sp>{Absolute or Gauge}<cr><lf>	Returns "Absolute" or "Gauge" for the pressure type.
83	RangeMax?	<sp>{value}<cr><lf>	Returns the maximum range of the active transducer and turndown in the current units.
84	RangeMin?	<sp>{value}<cr><lf>	Returns the minimum range of the active transducer and turndown in the current units.
85	Rate?	<sp>{value}<cr><lf>	Returns the rate reading of the instrument in current units/second.
86	Rdecpct?	<sp>{value}<cr><lf>	Returns the number of rate decimal points for the active channel. See: Resolution
87	Reference	{EXTVAC or ATM}	Sets the reference type for vacuum pump connected to the reference, or vented to atmosphere. This option is only available on native gauge units.
88	Reference?	<sp>{EXTVAC or ATM}<cr><lf>	Returns the current reference type of the active channel. See: Reference
89	Release?	{15 char string} Returns: <sp>(YES or NO), {string}<cr><lf>	This command is used to release control of the instrument when it is accessed by more than one computer. To release control of the instrument, {string} must be identifier used for the "Acquire" command. Yes if release is successful. No if instrument is being controlled with another computer. Return {string} = identifier of the controlling computer or AVAILABLE. See: Acquire? and Unlock.
90	Repeat	none	Repeats output continually over serial port only.

Continued on next page...

Table 4.1 - Continued

Ref	Command	Data	Function/Response
91	Resolution	{4 to 6}	Sets the number of significant digits. See: decpt
92	Resolution?	<sp>{value}<cr><lf>	Returns the number of significant digits.
93	Rsetpt	{value}	Sets the rate setpoint of the active channel in current units per second. Must be a value inside the current sensor range.
94	Rsetpt?	<sp>{value}<cr><lf>	Returns the current rate setpoint of the active channel in current units per second.
95	Sbaud	{9600, 19200, 38400, 57600}	Sets the serial baud rate.
96	Sbaud?	<sp>{value}<cr><lf>	Returns the serial baud rate.
97	Sdata	{7 or 8}	Sets the serial data bits.
98	Sdata?	<sp>{value}<cr><lf>	Returns the serial data bits number.
99	Sensor	C, X	Sets the active sensor where C = Primary or Secondary and X is the turndown.
100	Sensor?	<sp>C,X<cr><lf>	Returns the active sensor as above.
101	Sensor.acc	<sp>{value}<cr><lf>	Returns the accuracy of the sensor.
102	Sensorid?	<sp>{Address}<sp>MENSOR, <sp>600SNSR,<sp>{Serial No.},V{V.VV}<cr><lf>	Returns the active sensor's serial number and firmware version.
103	Setpt	{A value inside the upper/lower limits, and inside the range of the active transducer and turndown}	Sets the control setpoint for the active channel.
104	Setpt?	<sp>{value}<cr><lf>	Returns the control setpoint of the active channel in current units.
105	Span	{desired pressure or ?}	Sets span on active transducer (must be >50% FS, and within 1% limit), or ? to clear previous value.
106	Span?	<sp>{value}<cr><lf>	Returns span scale factor for active transducer and turndown.
107	Sparity	{Even, ODD , NONE}	Sets the serial parity.
108	Sparity?	{<sp>{string}<cr><lf>	Returns the serial parity.
109	Srqmask	Stable, Error or both	Sets the APC 600 to issue a service request (SRQ) over the IEEE-488 when the pressure control is stable, or an error occurs. These are 80 hex and 40 hex respectively.
110	Srqmask?	<sp>{string}<cr><lf>	Returns "stable", "error" or "error, stable" depending on the SRQ.
111	Sstop	{1 or 2}	Sets the serial stop bits.
112	Sstop?	<sp>{value}<cr><lf>	Returns the serial stop bits.
113	Stable?	<sp>{Yes or No}<cr><lf>	Returns YES if instrument is stable or NO.
114	Stabledelay	{0 to 65535}	Sets the stable time to the number of seconds specified.
115	Stabledelay?	<sp>{value}<cr><lf>	Returns the stable time.
116	Stabletime	{0 to 65535}	Sets the stable time to the number of seconds specified.
117	Stabletime?	<sp>{value}<cr><lf>	Returns the stable time.
118	StableWin	{%fs value}	Sets the stable window as a %FS.
119	StableWin?	<sp>{value}<cr><lf>	Returns the stable window in % of Span.
120	Standby	none	Instrument placed in Standby mode, all solenoids de-energized.
121	Standby?	<sp>{Yes or No}<cr><lf>	Returns YES if the active channel is in Standby, NO if otherwise.
122	Step	<sp>{value inside upper and lower limits and inside the range of the active sensor and turndown}<cr><lf>	Sets the control step size for the instrument.

Continued on next page...

Table 4.1 - Continued

Ref	Command	Data	Function/Response
123	Step-	{none or value}	Jogs the setpoint down one step. If a value is entered, sets the step size to that value.
124	Step+	{none or value}	Jogs the setpoint up one step. If a value is entered, sets the step size to that value.
125	Step?	<sp>{value}<cr><lf>	Returns the control step for the instrument.
126	Stop	none	Stop repeating output over serial port. See: Repeat
127	Units	{units code, or output format text from Measurement Units table 9.1 in <i>Appendix</i> section}	Sets the instrument engineering units.
128	Units?	<sp>{string}<cr><lf>	Returns the instrument units in a text string.
129	Unlock	none	Releases Acquire locks. See: Acquire? and Release?
130	UpperLimit	{Value inside primary transducer range}	Sets the upper control limit for the active channel.
131	UpperLimit?	<sp>{value}<cr><lf>	Returns the upper control limit for the active channel.
132	Vent	none	Instrument placed in Vent mode.
133	Vent?	<sp>{Yes or No}<cr><lf>	Returns YES if active channel is in Vent mode, No if otherwise.
134	Versions?	<sp>{string}<cr><lf>	Returns the versions of the firmware for the instrument, gpib driver, gate array, installer, and the graphics library.
135	Volume	{value in cc}	Sets the system volume in cc's – only applicable if the active channel is a low pressure regulator.
136	Volume?	<sp>{value}<cr><lf>	Returns the current system volume in cc's – only applicable if the active channel is a low pressure regulator.
137	Zero	{desired pressure or ?}	Sets active sensor and turndown's zero to entered pressure, or ? to clear previous value.
138	Zero?	<sp>{value}<cr><lf>	Returns zero offset value for active sensor and turndown.

Table 4.2 - APC 600 Error Codes

Code	Serial Poll Byte	Description	Error String Returned
E00	00h	reserved	unused code
E01	41h	GPIB listen/talk error	GPIB LISTEN/TALK ERROR
E02	42h	Syntax error	UNKNOWN COMMAND
E03	43h	Expected a valid _PCS4 command	EXPECTED A VALID _PCS4 COMMAND
E04	44h	Expected a valid FUNC command	EXPECTED A VALID FUNC COMMAND
E05	45h	Expected a valid CAL command	EXPECTED A VALID CAL COMMAND
E06	46h	Expected a valid TEST command	EXPECTED A VALID TEST COMMAND
E07	47h	Expected a pressure units selection	EXPECTED A PRESSURE UNITS SELECTION OR INVALID TERMINATION STRING
E08	48h	Expected a pressure value	EXPECTED A PRESSURE VALUE
E09	49h	Expected a transducer selection	EXPECTED A XDUCER SELECTION
E10	4ah	Expected a seconds selection	EXPECTED A SECONDS SELECTION
E11	4bh	reserved	unused code
E12	4ch	reserved	unused code
E13	4dh	Invalid pressure units selection	INVALID PRESSURE UNITS SELECTION
E14	4eh	Invalid control pressure value selection	INVALID CONTROL PRESSURE VALUE SELECTION
D15	4fh	Invalid rate value selection	INVALID RATE VALUE SELECTION
E16	50h	Invalid a/d unit selection	INVALID A/D UNIT SELECTION
E17	51h	Invalid zero offset value selection	INVALID ZERO OFFSET VALUE SELECTION
E18	52h	Invalid Span offset value selection	INVALID SPAN OFFSET VALUE SELECTION
E19	53h	Invalid rate units selection	INVALID RATE UNITS SELECTION
E20	54h	Sensor overrange	SENSOR OVERRANGE
E21	55h	Sensor underrange	SENSOR UNDERRANGE
E22	56h	Sensor failure detected	SENSOR FAILURE DETECTED
E23	57h	Low source pressure	LOW SOURCE PRESSURE
E24	58h	Regulator failure detected	REGULATOR FAILURE DETECTED
E25	59h	reserved	unused code
E26	5ah	Internal leak detected	INTERNAL LEAK DETECTED
E27	5bh	Program error detected	PROGRAM ERROR DETECTED
E28	5ch	Memory error detected	MEMORY/COEFFICIENT ERROR DETECTED
E29	5dh	External Leak detected	EXTERNAL LEAK DETECTED
E30	5eh	High exhaust pressure	VACUUM ERROR DETECTED
E31	5fh	Transducer error detected	XDUCER ERROR DETECTED
E32	60h	Invalid transducer selection	INVALID TRANSDUCER SELECTION
E33	61h	Invalid filter window selection	INVALID FILTER WINDOW SELECTION
E34	62h	Invalid filter setting selection	INVALID FILTER SETTING SELECTION
E35	63h	Invalid output format selection	NOT A VALID OUTPUT FORM SELECTION
E36	64h	Invalid stable window selection	INVALID STABLE WINDOW SELECTION
E37	65h	Invalid stable delay selection	INVALID STABLE DELAY SELECTION
E38	66h	reserved	unused code

Continued on next page...

Table 4.2 - Continued

Code	Serial Poll Byte	Description	Error String Returned
E39	67h	Expected a filter setting selection	EXPECTED A FILTER SETTING SELECTION
E40	68h	Expected an output format selection	EXPECTED AN OUTPUT FORM SELECTION
E41	69h	Expected a stable delay selection	EXPECTED A STABLE DELAY SELECTION
E42	6ah	Expected a language selection	EXPECTED A LANGUAGE SELECTION
E43	6bh	reserved	unused code
E44	6ch	reserved	unused code
E45	6dh	PCS200 command format error	PCS200 COMMAND FORMAT ERROR
E46	6eh	Control pressure overrange	CONTROL PRESSURE OVERRANGE
E47	6fh	Control pressure underrange	CONTROL PRESSURE UNDERRANGE
E48	70h	Illegal GPIB controller function	ILLEGAL GPIB CONTROLLER FUNCTION
E49	71h	GPIB error	GPIB ERROR
E50	72h	Invalid termination	INVALID TERMINATION
E51	73h	Vent mode disabled	VENT MODE DISABLED
E52	74h	Special functions not available	SPECIAL FUNCTIONS NOT AVAILABLE
E53	75h	reserved	unused code
E54	76h	Expected a valid DPC-179 command	EXPECTED A VALID DPC-179 COMMAND
E55	77h	Expected a valid DPC-179 header command	EXPECTED A VALID DPC-179 HEADER COMMAND
E56	78h	Expected a valid DPC-179 control command	EXPECTED A VALID DPC-179 CONTROL COMMAND
E57	79h	reserved	unused code
E58	7ah	reserved	unused code
E59	7bh	reserved	unused code
E60	7ch	reserved	unused code
E61	7dh	reserved	unused code
E62	7eh	reserved	unused code
E63	7fh	cal functions disabled	CAL FUNCTIONS DISABLED

SCPI Commands**STATUS**

:OPERation
:CONDition?

Returns an integer value representing instrument status that can be decoded.

Bit 0: Zeroing active.

Bit 1: Control Setpoint has not been reached.

Bit 2: Reserved 0.

Bit 3: Reserved 0.

Bit 4: Measuring. The instrument is actively measuring.

MEASURE

[:PRESsure] [z]?
:TEMPerature[z]?
:RATE[z]?
:BAROmetric?

Returns the pressure from the active sensor, or active sensor if [z] is omitted.

Returns the temperature in deg. C. from the specified sensor, or active sensor if [z] is omitted.

Returns the pressure rate from the specified sensor, or active sensor if [z] is omitted.

Returns the barometric pressure, if a barometer sensor is installed.

CALIBRATION

:MODE?
:DATE?

:DATE <i,i,i>
:ZERO?
:ZERO <n>

ZERO:RUN

Returns 1 if the sensor has been calibrated or 0 if not.
Returns the stored calibration date.

Sets the calibration date (YYYY,MM,DD).

Returns current zero point correction.

Sets the zero so the currently measured pressure matches the commanded value. Limited to +/-5% FS.

Vents the instrument and sets zero so the currently measured pressure = 0.

SENSE

[:PRESsure] [z]

:NAME?
:MODE?
:MODE ABS/GAUGE
:ABS?
:RESolution?
:RANGE
 [:UPPer]?
 :LOWer?
:Unit
 [:NAME]?
 :VALue?

:REFerence
 [:HEIGHT] <n>
:MODE?
:MODE OFF/GAS/LIQUIT
:MEDIUM <n>

Selects the sensor to read or modify or active sensor if [z] is omitted.

Returns the accuracy and range of the sensor.

Returns pressure type "ABSOLUTE" or "GAUGE"

Sets the pressure type to absolute or gauge.

Returns native sensor type "1" for absolute, "0" for gauge.

Returns the FS-related relative resolution of the sensor.

Returns the maximum range of the primary sensor.

Returns the minimum range of the primary sensor.

Returns a string representing the native units of the sensor.

Returns the conversion factor of the native units of the sensor.

Sets the head height correction [mm].

Returns head correction mode - "OFF", "GAS", LIQUIT".

Sets the head correction mode.

Sets the density of the medium.

SYStem

:DATE <i,i,i> Sets the system date (YY,MM,DD).
 :TIME <i,i,i> Sets the system time (hh,mm,ss).
 :ERRor[:NEXT]? Return: error#, "description".
 :KLOCK ON/OFF/1/0 Lock or unlock keyboard.
 :PRESet Load known values.
 :SAVE Saves settings to non-volatile memory.
 :VERSion? Return of the SCPI-standard.

TEST

:ELECTronic? Returns electronics status.
 :RELay<n>? Returns whether relay t to 3 is closed or not.
 :RELay<n> ON/OFF Turns relay 1 to 3 on or off.

UNIT

:NAME<n>? Returns the name of the unit with index n.
 :FACTOR<n>? Returns the conversion factor of the unit with index n.

index	unit
0	bar
1	mbar
2	Pa
3	psi
4	atm
5	kp/cm ²
6	lbf/ft ²
7	kPa
8	cmH2O(4°C)
9	inH2O(4°C)
10	inH2O(60°F)
11	ftH2O(4°C)
12	μmHg(0°C)
13	mmHg(0°C)
14	cmHg(4°C)
15	inHg(0°C)
16	inHg(60°F)
17	--
18	user
19	user
20	user

OUTPut

:STATE ON/OFF/1/0 Turns control mode on or off.
 :STATE? Returns control mode "0" for off, "1" for on.
 :MODE MEASure/CONTrol/VENT Sets the operation mode.
 :MODE? Returns current operation mode MEASURE", "CONTROL" or "VENT".
 :STABLE? Returns 1 if in control mode and stable.
 :AUTOvent ON/OFF/1/0 Sets autovent function on or off (automatically vent when controlling at zero).
 :AUTOvent? Returns status of Autovent function.

[SOURCE]

:PRESsure
 [:LEVel]
 [:IMMediate]
 [:AMPLitude] <n> Sets the control pressure.
 [:AMPLitude]? Returns current control pressure value.
 :SLEW <n> Sets the slew rate in %FS/s.
 :SLEW? Returns the current slew value in %FS/s.
 :TOLerance <n> Sets the tolerance for stable indication in %FS.
 :TOLerance? Returns the tolerance for stable indication in %FS.

CALCulate

:LIMit
 :LOWer <n> Sets minimum control limit.
 :LOWer? Returns minimum control limit.
 :UPPer <n> Sets maximum control limit.
 :UPPer? Returns maximum control limit.

Output Formats

1. <sp>pressure value<cr><lf>
2. <sp>pressure, units number, mode<cr><lf>
3. <sp>pressure, pressure rate<cr><lf>
4. <sp>pressure, minimum peak, maximum peak<cr><lf>
5. <sp>pressure, active sensor (P or S) active turndown (1-4)<cr><lf>
6. <sp>pressure, control point, "stable" or "slewing"<cr><lf>
7. <sp>pressure, "no barometer" or baro reading<cr><lf>

Error Messages and Error Codes

A recognized command is displayed at the device in the headline with "Remote...". In case of error "Remote error..." is displayed. A maximum of 100 errors are stored and can be retrieved successfully.

Table 4.3 - SCPI Command Error Messages and Error Codes

Code	Error String Returned
0	No error
-101	Undefined character
-102	Syntax error
-103	Undefined separator
-104	Parameter data type error
-109	Parameter missing
-110	Undefined header
-113	Undefined command
-114	Parameter out of range
-313	Calibration data not found

Continued on next page...

Table 4.3 - Continued

-315	Configuration data not found
-350	Errorqueue overflow
-410	Query interrupted
600	Default configuration not found
601	Calibration mode active! Deactivate before setting C0..C3
602	Sensor not available
701	DCS instance not available
702	Create DCS instance failed
703	DCS still active
704	Command currently not allowed

Remote Emulation

The Mensor PCS 400 is an earlier generation instrument similar to the APC 600. There is some compatibility between the APC 600 and a PCS 400 in that the APC 600 will respond to many of the remote instructions as if it were the older instrument. The PCS 400 commands will operate only on the currently active control channel.

Table 4.4 is a list of the remote commands and queries which the APC 600 will recognize and respond to.

A space between elements in a command indicate a required delimiter. Use a space where such a delimiter is indicated. A full description of the syntax and use for each of these commands and queries are presented in the PCS 400 manual.

NOTE: All pressure values will be in the currently active pressure units unless otherwise stated.

PCS 400 Emulated Commands/Queries

Table 4.4 - PCS 400 Emulated Commands/Queries

Ref	Command	Data	Function/Response
1	_pcs4 autorange <value>	0 or 1	1 turns autorange on, 0 turns autorange off.
2	_pcs4 autorange?		Returns 1 if in autorange, 0 if in range hold.
3	_pcs4 cal span <value>		Sets the span of the active transducer to <value>.
4	_pcs4 cal zero <value>		Sets the zero of the active transducer to <value>.
5	_pcs4 cal_disable_off		Enables zero or span calibrations if previously disabled.
6	_pcs4 cal_disable_on		Prevents zero or span calibrations.
7	_pcs4 ctrl <value>		Sets control value. Will take effect immediately if instrument is in control mode.
8	_pcs4 ctrl?		Returns the current control point in current engineering units.
9	_pcs4 ctrlmax <value>		Sets maximum control value.
10	_pcs4 ctrlmax?		Returns current maximum control pressure.
11	_pcs4 ctrlmin <value>		Sets minimum control value.
12	_pcs4 ctrlmin?		Returns current minimum control pressure.
13	_pcs4 default		Sets default values into instrument.
14	_pcs4 err?		Returns the error number and description.
15	_pcs4 func ctrl <value> <unitno>		Instrument placed in control mode at <value> pressure in <unitno> units.
16	_pcs4 func F1		Toggles between absolute and gauge modes if an internal barometric sensor is installed.
17	_pcs4 func meas		Instrument placed in measure mode.
18	_pcs4 func stby <unitno>		Instrument placed in standby mode in <unitno> units.
19	_pcs4 func vent <unitno>		Instrument placed in vent mode in <unitno> units.
20	_pcs4 id?		Returns instrument ID.
21	_pcs4 opt?		Returns instrument options.
22	_pcs4 outform <digit>		Sets output format.
23	_pcs4 outform?		Returns the current output format.
24	_pcs4 rangemin?		Returns the minimum pressure of the active transducer.
25	_pcs4 span?		Returns the stored multiplication factor from the active transducer and turndown.
26	_pcs4 stabledelay <value>	1 to 255	Sets the number of consecutive readings that the pressure must remain within the stable window for a pressure stable indication.
27	_pcs4 stabledelay?		Returns the number of readings that must be within the stable window before a stable pressure is indicated.
28	_pcs4 stablewindow <value>		Sets the pressure window that is used to indicate pressure is stable.
29	_pcs4 stablewindow?		Returns the pressure tolerance allowed for a stable pressure indication as a % of span of the active transducer.
30	_pcs4 stat?		Returns mode and stable flag status "mode, stable CR LF".
31	_pcs4 unit <unitno>		Sets the instrument to specified engineering units.
32	_pcs4 unit?		Returns the current engineering units and type of transducer (A, G, D).
33	_pcs4 xducer?		Returns the number of the currently active transducer.
34	_pcs4 zero?		Returns the stored zero offset of the active transducer and turndown in the current pressure units.

PCS 200 Emulated Commands/Queries

Table 4.5 - PCS 200 Emulated Commands/Queries

Men	Command	Data	Response/Function
	CX		Control Pressure at last control point and units
	C\$nnnnnnnX		Control Pressure at n in units \$
	C\$nnnnnnnsX		Control Pressure at n in units \$
	D#X		CAL POINT CONTROL MODE NOT SUPPORTED
	EX		Clear Error/Clear Service Request
	E?X		Return error code and clear error
	F\$nnnnnnn1X		Re-initialize; \$,n ignored
	F\$nnnnnnn2X		RETURN CAL DATA NOT SUPPORTED
	F\$nnnnnnn3X		Return Unit ID string; \$,n ignored
	F\$nnnnnnn5X		RETURN QPS TEMPERATURE NOT SUPPORTED
	F\$nnnnnnn6X		RETURN NULL METER READING NOT SUPPORTED
	F\$nnnnnnn7X		RETURN VACUUM GAUGE READING NOT SUPPORTED
	F\$nnnnnnn8X		Return Clock Reading (Time); \$,n ignored
	F\$nnnnnnn9X		Return Pressure Control Limits; \$,n ignored
	MX		Measure Pressure in current pressure units
	M\$X		Measure Pressure in units specified by \$
	M\$nnnnnnnX		Measure Pressure in units specified by \$; n ignored
	M\$nnnnnnnsX		Measure Pressure in units specified by \$; n,s ignored
	Q#X		SEQ FUNCTIONS NOT SUPPORTED
	RX		Not supported
	R0X		Return to Standard Output Format
	R1X		Re-initialize DO NOT USE - sets APC 600 to command prompt.
	R2X		RETURN CAL DATA NOT SUPPORTED
	R3X		Return unit ID string
	R5X		RETURN QPS TEMPERATURE NOT SUPPORTED
	R6X		RETURN NULL METER READING NOT SUPPORTED
	R7X		RETURN VACUUM GAUGE READING NOT SUPPORTED
	R8X		Return Clock Reading (Time)
	R9X		Return Pressure Control Limits (Min and Max)
	SX		Standby Mode
	S\$X		Standby Mode; \$ ignored
	S\$nnnnnnnX		Standby Mode; \$,n ignored
	S\$nnnnnnnsX		Standby Mode; \$,n,s ignored
	U\$X		Change Units to units specified by \$
	VX		Vent Mode in current units
	V\$X		Vent Mode in units specified by \$
	V\$nnnnnnnX		Vent Mode in units specified by \$; n ignored
	V\$nnnnnnnsX		Vent Mode in units specified by \$; n,s ignored
	ZX		Automatic re-zero

User's Notes:

A large rectangular area filled with a fine grid of small squares, intended for taking notes. A vertical yellow line runs down the left side of the grid, approximately one-fifth of the way from the left edge. The grid is otherwise empty.

Section 5: MAINTENANCE

The APC 600 was designed for maintenance-free operation. User maintenance is not recommended beyond replacement of parts listed in Table 5.1. If you have questions not covered by this manual, call 1.800.984.4200 (USA only), or 1.512.396.4200 for assistance, or send an e-mail to tech.support@mentor.com.

BEYOND THE WARRANTY

Take advantage of Mensor's expert product care. Mensor Corporation provides complete maintenance and calibration services, available for a nominal fee. Our service staff is knowledgeable in the innermost details of all of our instruments. We maintain units that are in operation in many different industries and in a variety of applications, and by users with a wide range of requirements. Many of these instruments have been in service for over twenty years, and continue to produce excellent results. Returning your instrument to Mensor for service benefits you in several ways:

1. Our extensive knowledge of the instrument assures you that it will receive expert care.
2. In many cases we can economically upgrade an older instrument to the latest improvements.
3. Servicing our own instruments which are used in "real world" applications keeps us informed as to the most frequent services required. We use this knowledge in our continuing effort to design better and more robust instruments.

TROUBLESHOOTING THE PNEUMATIC SYSTEM OF THE APC 600



PROCEED WITH CAUTION:
The following test feature is a powerful troubleshooting tool, but it incurs a dangerous potential for misdirecting high pressures. Study the pneumatic schematics (Figures 5.3 & 5.6) to understand the possible consequences of various pressure routings.

Low Range Pressure Regulator

The APC 600 has two Controller test screens; one is for low range pressure and the other for mid range pressure (Figures 5.1 and 5.4).

The test key is used to enter a test mode that gives the user individual control of all solenoids. To get to the

test screen showing the schematic for low range pressure (Figure 5.1) press [Setup], [Controller], and [Test].

See Figure 5.3 for the pneumatic schematic for low range pressure.

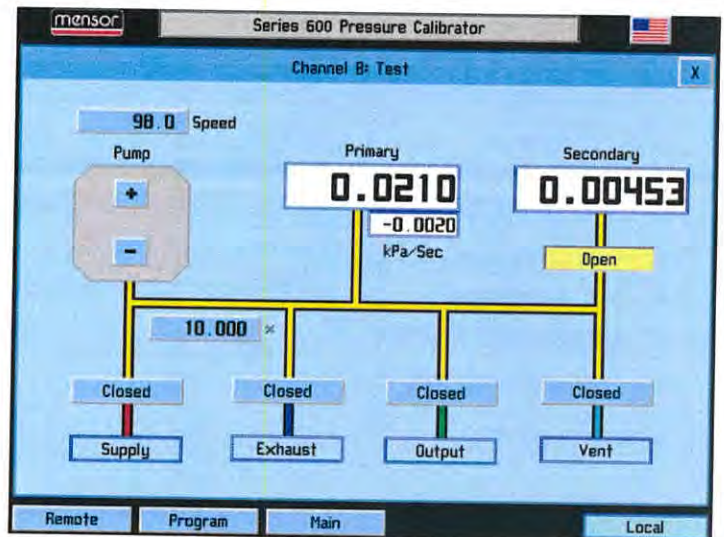

Figure 5.1 - Test Screen, Low Pressure

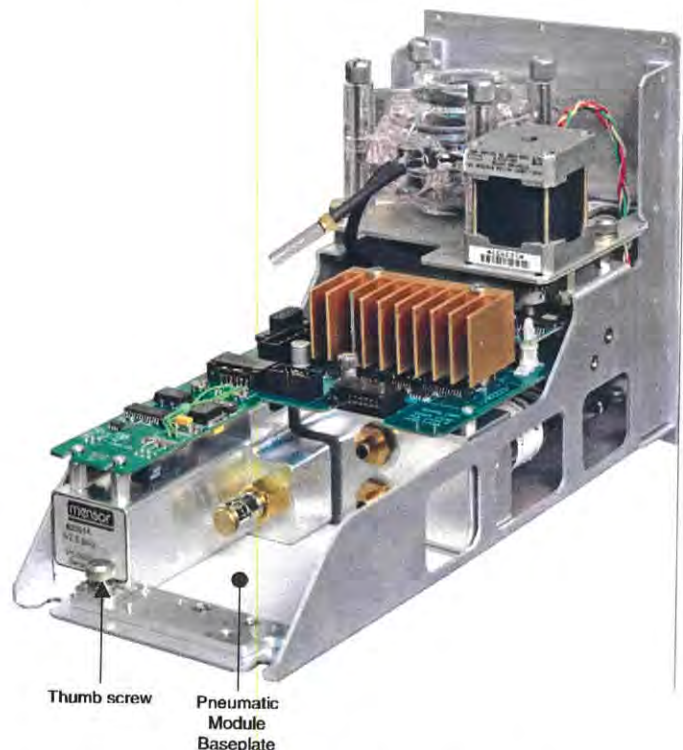

Figure 5.2 - Pneumatic Module, Low Pressure

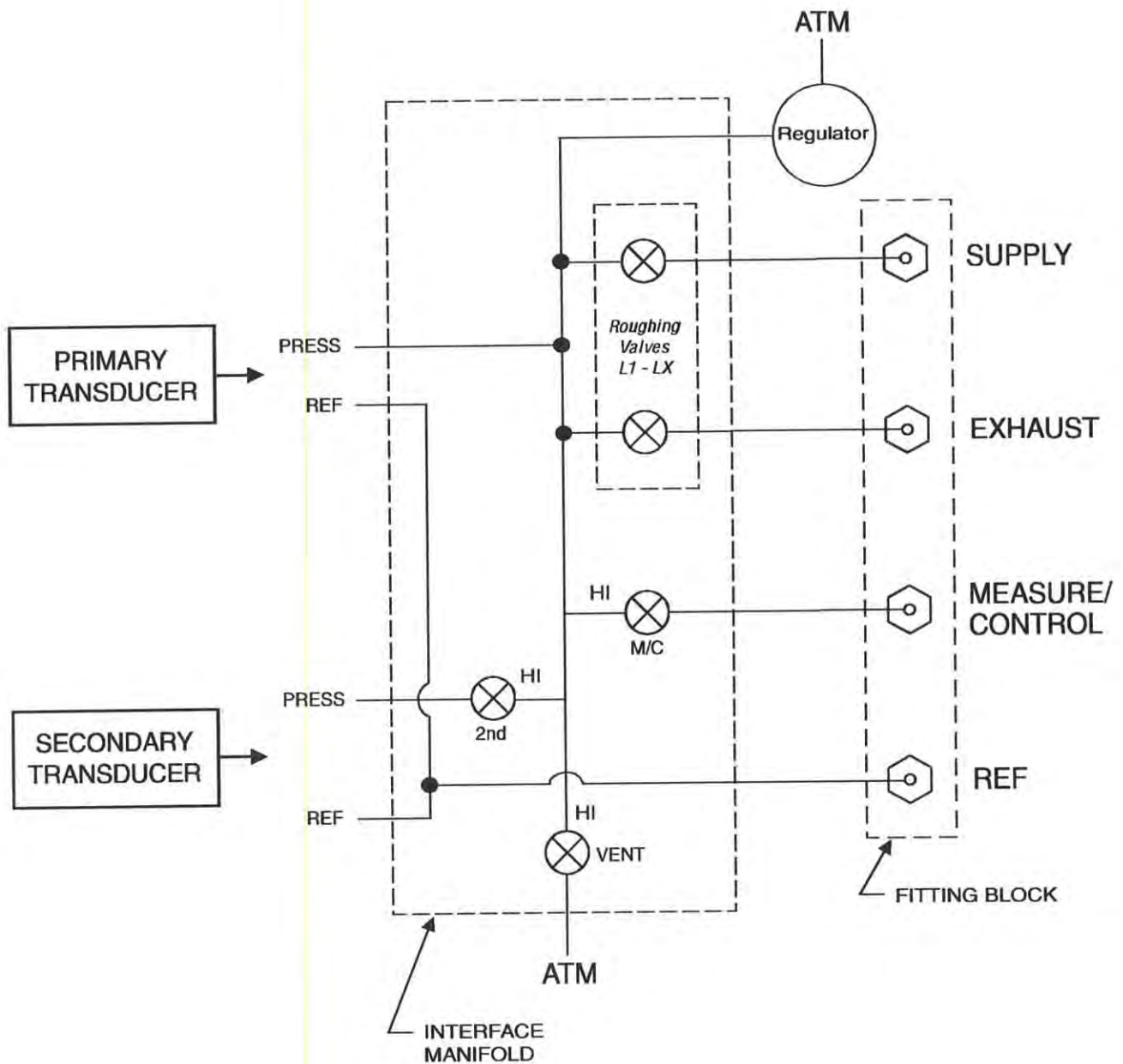

Figure 5.3 - Pneumatic Schematic - Low Range Pressure

Mid Range Pressure Regulator

The test key is used to enter a test mode that gives the user individual control of all solenoids. To get to the test screen showing the schematic for mid range pressure (Figure 5.4) press [Setup], [Controller], and [Test].

See Figure 5.6 for the pneumatic schematic for mid range pressure.

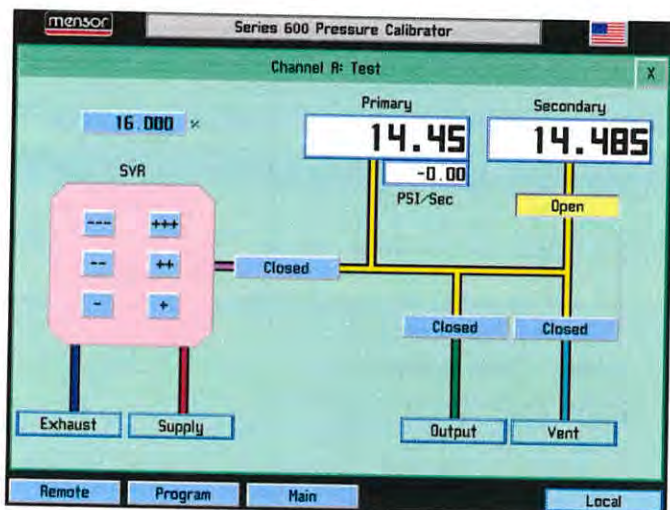

Figure 5.4 - Test Screen, Mid Pressure

Tuning a Mid Range Regulator Module

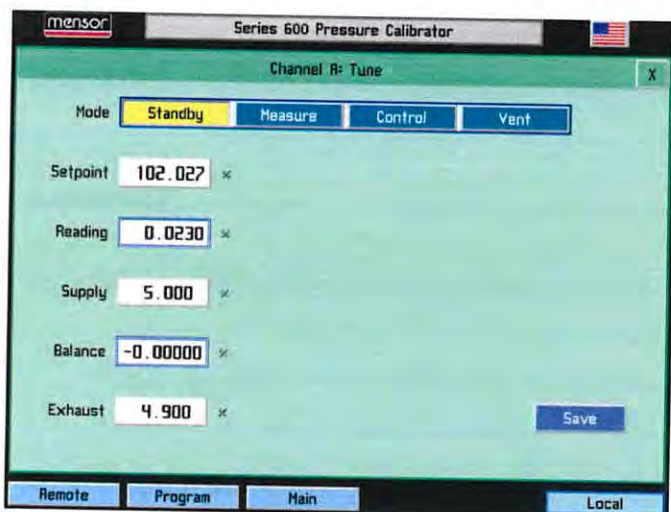

Figure 5.5 - Tune Screen, Mid Pressure

Modes

[Standby] seals all outside connections.

[Measure] isolates the active sensor and measure/control port.

[Control] controls to displayed setpoint in % F.S.

[Vent] opens manifold to atmosphere.

Setpoint = desired pressure in % F.S.

Reading = measured pressure in % F.S.

Supply = supply fine and bleed valve

Balance = balance between supply and exhaust fine valves

Exhaust = exhaust fine bleed valve

[SAVE] saves the supply and exhaust fine bleed valves to the regulator.

Typical supply and exhaust values will be 3.00 to 6.00.

Tuning Procedure

1. Plug Measure/Control port.
2. Connect supply pressure equal to 110% of the maximum range for that channel and a vacuum pump if necessary.
3. Press [SETUP] [CONTROLLER] [TUNE] on the channel you wish to tune.
4. Press the box to the right of the Setpoint and enter 50.00 and [OK].
5. Push the [CONTROL] button and watch the value in the box to the right of Reading climb towards the setpoint.
6. If the Reading stays below the Setpoint increase the Supply value by .1 until the setpoint is reached.
7. Again press the box to the right of Setpoint and enter 25.00 and [OK].
8. If the Reading stays above the Setpoint increase the Exhaust value by .1 until the setpoint is reached.
9. Return again to the Setpoint of 50 by repeating step 4.
10. Evaluate the way the reading reacts when approaching the setpoint and repeat steps 6 and 8 until the desired result is reached.
11. When you are satisfied with the performance of the regulator, press the [SAVE] button to store the changes you have made to the regulator. These values are stored in nonvolatile memory on the regulator and they will be saved through power cycles.

Regulator Valves

Figure 5.4 shows [Open/Closed] keys for the four regulator modulating valves. These valves can be operated from this screen to perform diagnostic tests on the regulator. The relationship between the "+" and "-" symbols and the regulator are:

- +++ = Roughing Supply Valve
- ++ = Medium Supply Valve
- + = Fine Supply Valve
- = Fine Exhaust Valve
- = Medium Exhaust Valve
- = Roughing Exhaust Valve

When a key is pressed the regulator valve operates to let pressure into or out of the regulated pressure trunk. The flow rate can be adjusted using the [%

duty cycle entry] key on the top left corner. Observe these values while operating the valves for trouble shooting purposes.

If the supply valves are left open until the pressure in the regulated pressure trunk exceeds the pressure range of the currently selected turndown in Range Hold mode, or the maximum range of the primary transducer in Autorange mode, the test will automatically terminate.

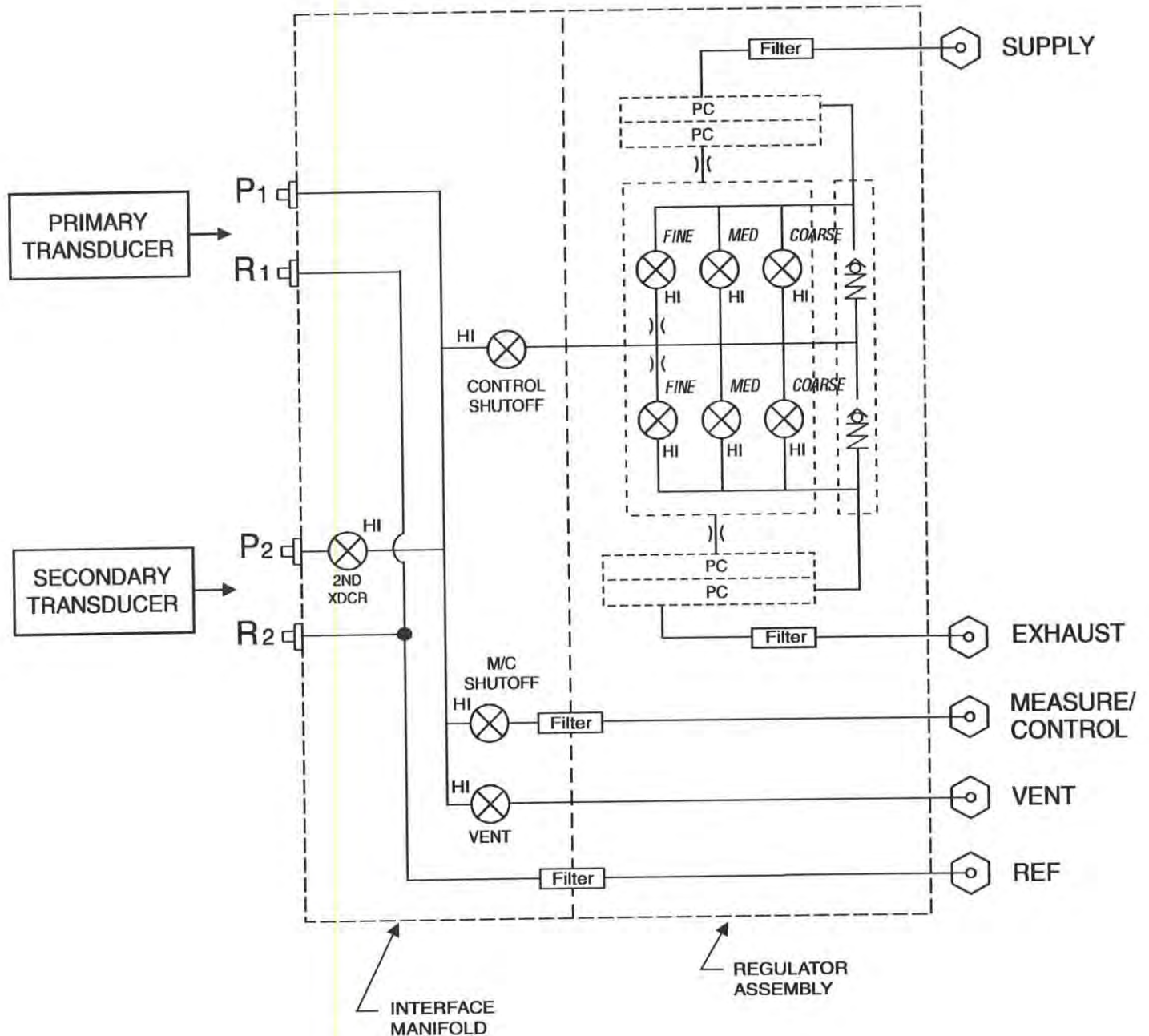

Figure 5.6 - Pneumatic Schematic - Mid Range Pressure

Pneumatic Module Solenoids



PROCEED WITH CAUTION: The following test feature is a powerful troubleshooting tool, but it incurs a dangerous potential for misdirecting high pressures. Study the pneumatic schematics (Figures 5.3 & 5.6) to understand the possible consequences of various pressure routings.

In figures 5.1 and 5.4 each key is an [Open/Closed] toggle. As each key is pressed the key will change text and color, and the target solenoid will make an audible "click". If a key changes color without the accompanying click it's an indication of a defective solenoid or a bad connection.

NOTE: If you intend to exceed the pressure of the secondary transducer, the solenoid directly below its reading should be closed.

REPLACING MODULES



CAUTION: ESD PROTECTION REQUIRED. The proper use of grounded work surfaces and personal wrist straps are required when coming into contact with exposed circuits (printed circuit boards) to prevent static discharge damage to sensitive electronic components.

Always store loose transducers and PC boards in static protective bags or containers.

Transducer Removal

1. **VENT THE SYSTEM!** Then turn off the power.
2. Loosen the two captive screws on the front panel (Figure 1.2), and swing the panel open.
3. Unscrew the thumb screw holding in the transducer (Figures 5.2 and 5.7).
4. Apply a light inward pressure against the bottom of the transducer case, just below the range label, while tilting the case upward to clear the clamp plate and screw head.
5. Pull the transducer module outward, through the front opening.



CAUTION: There must be a transducer installed in the "Primary Transducer" berth for the system to function properly. If the system is operated with the primary berth empty the results will be unpredictable.

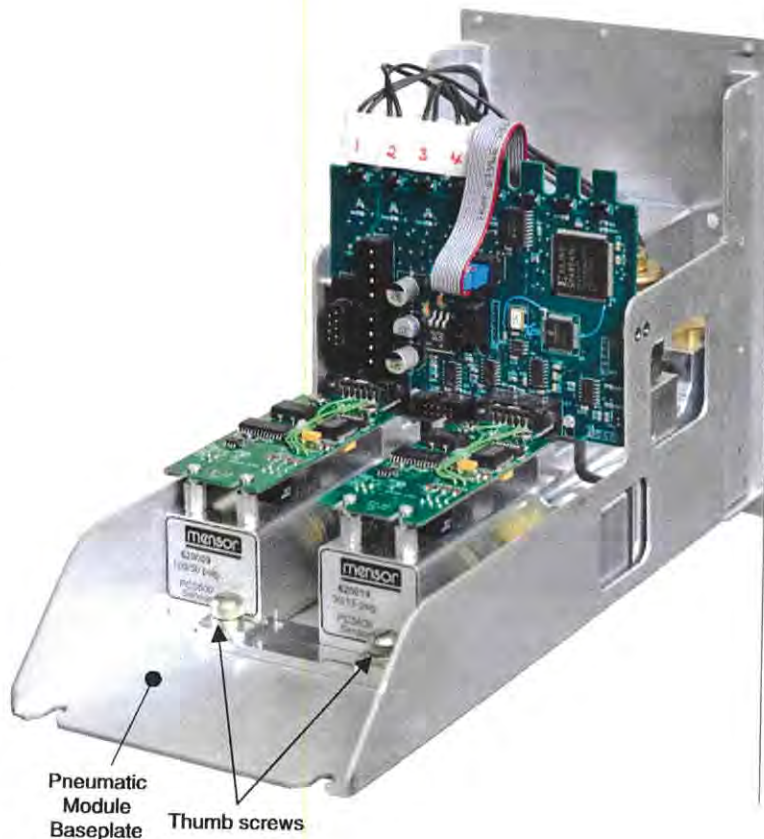

Fig. 5.7 - Pneumatic Module, Mid/High Range Pressure

Removing a transducer disengages the electrical and pneumatic connections and seals off the pressure on the pneumatic module. This permits the APC 600 to be turned on with the supply pressure connected even with no transducers installed.

NOTE: Each control channel has pressure control limits. Typically, the low pressure control modules have a maximum limit of 15 psig and the mid range control modules have limits of 150 or 1500 psig. If a sensor is placed into a control channel where the sensor has a higher upper pressure range than the control module, the maximum control limit will be limited to the maximum range of the control module.

While any sensor will function in any control channel, the results may not always be optimum. For example if a 1 psi sensor is placed in a control module that has a 1500 psi upper limit, the control stability may not be acceptable. Or if a 1500 psi module is placed in a control module that has a 30 psi upper limit, it will control very well, but be limited in resolution.



CAUTION: When transducers are replaced and the unit is re-booted, the default parameters will be loaded. If you are using custom settings they must be reloaded after transducer installation.



CAUTION: Do not install a high pressure transducer into a low pressure APC 600. It is acceptable to install a low pressure transducer in a high pressure instrument, but control stability will be degraded.



CAUTION: Do not mix gauge and absolute pressure sensors on one control channel!

Transducer Installation

To replace a transducer first make sure that it is going into the proper transducer berth in the pneumatic module. Each berth is clearly marked on the pneumatic module baseplate. See Figure 1.5. The "PRIMARY TRANSDUCER" must be the transducer with the highest pressure range.

To install a transducer with the front panel already open:

1. Rest the transducer on the baseplate and the retention bar. The transducer will be tilted down slightly.
2. Slide the transducer inward until resistance is felt. Then apply enough pressure against the transducer for it to clear the clamp so that it clears the retention bar and is fully seated and level on the baseplate.
3. Tighten the thumb screw to secure the transducer.
4. Swing the front panel closed and secure it by tightening the two captive screws.

Pneumatic Module Removal

1. **VENT THE SYSTEM!** Then turn off the power.
2. Remove cover.
3. Remove all external pressure connections.
4. Remove the slotted 2.5mm screw that screws into the rear pressure manifold.
5. Inside the pneumatic module disconnect one 9-pin D-sub connector at the regulator, and the two connectors on the power cable.

6. Slide the pneumatic module out through the rear and clear of the chassis.

NOTE: Pneumatic modules have EMI containment strips that may necessitate some force to remove modules.

Pneumatic Module Installation

To install or replace the pneumatic module, simply reverse the steps taken for its removal.

SPARE PARTS LIST

Table 5.1 lists the spare parts for the APC 600 that can be ordered from Mensor.

Table 5.1 – Spare Parts

Part Description	Part Number
Operation Manual	0017222001
Fuses	4100111150
Power Cord	4000400002
Power Supply	0017589001
Fitting Adapter - 7/16-20 to 1/8 FNPT	6000602015
Fitting Adapter - 7/16-20 to 1/4 FNPT	0012688001
O-ring seals for 7/16-20 Fitting	4250010020
Power Module Assembly	0017203001
Motherboard	4904000059
Pneumatics Module – <15 psig	0017207001
Pneumatics Module – 0-150	0017560001
Pneumatics Module – 0-1500	0017560002
Pump Regulator Assembly – <15 psi	0017213001
Regulator Assembly – 0-150 psi	0017562001
Regulator Assembly – 0-1500 psi	0017562002
Regulator Cap Assembly 0-150 psi	0017623001
Regulator Cap Assembly 0-1500 psi	0017623002
Solenoid Valve – Low <150 psi	6100300038
Solenoid Valve – Mid (150 to 1500)	6100300037
Pressure Transducer – Primary or Secondary (Calibrated)	0017218XXX Consult Mensor for specific ranges.
Calibration Sled Kit	0017657001



Figure 5.8 - Chassis Interior, Top View

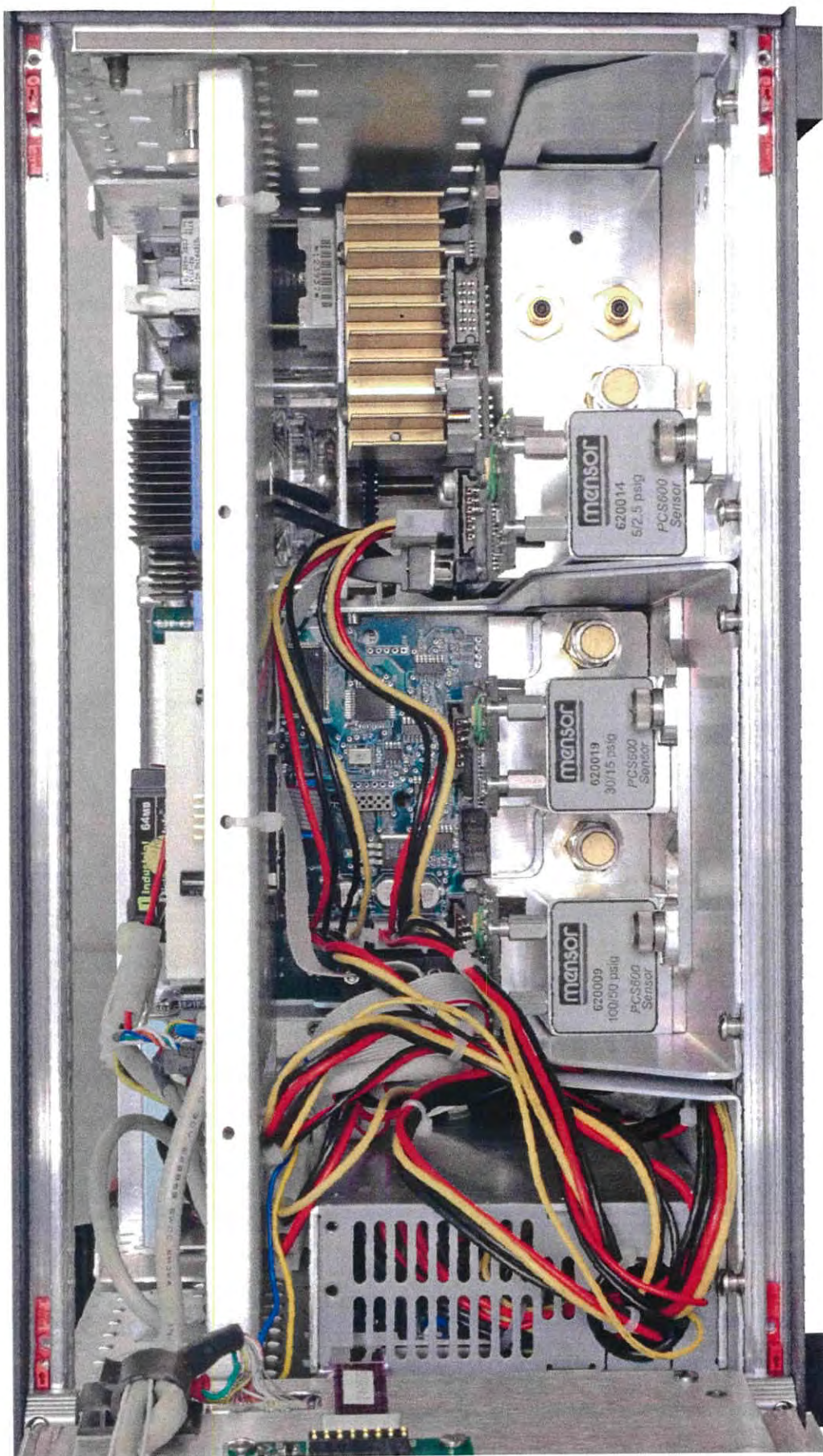

Figure 5.9 - Chassis Interior, Front View

Section 6: CALIBRATION

GENERAL

The APC 600 automatically adjusts the pressure reading for the effects of temperature and non-linearity within the calibrated temperature range of 15-45°C. The process is referred to as dynamic compensation because each reading is so adjusted before it is output to the display or to a communication bus. Thus, a calibrated APC 600 operated within its temperature band, and with proper zero and span adjustments, will provide accurate pressure measurements.

The APC 600 should have the calibration verified periodically on all turndowns to insure stability. The recommended calibration cycle is six months.

ENVIRONMENT

For maximum accuracy, allow the APC 600 to warm up for a minimum of 15 minutes in an ambient temperature within the compensated range prior to commencing a calibration. In addition the instrument should be at rest on a stable platform that is free of excessive vibration and shock.

PRESSURE STANDARDS

Mensor recommends the use of appropriately accurate primary pressure standards when calibrating this instrument. Such standards should be sufficient so that when the techniques of the *ISO Guide to the Expression of Uncertainty in Measurement* (GUM) are applied, the instrument meets its accuracy statements as required by ISO/IEC 17025:2005, or other applicable standards.

MEDIA

The recommended calibration medium is dry nitrogen or clean dry instrument air. A height variation between the standard and the APC 600 can cause significant errors. See 'Head Pressure Correction' in the *Calibration* Section for further information.

SETUP

Figure 6.1 (Calibration Setup) illustrates a typical setup for either local or remote calibration for an absolute or gauge pressure instrument. In the illustration the 'Optional Computer' is required only for performing a remote calibration.

The 'Pressure Standard' is normally a deadweight test instrument, and the 'Volume Controller' refers to a hand operated variable-volume pressure vernier device. A diaphragm type vacuum gauge is recommended over the gauge tube type of vacuum sensor for calibrating sub-atmospheric pressures (see Figure 6.1, under "Setup for Absolute Pressure"). A vacuum source with a capacity of generating 600 millitorr is recommended.

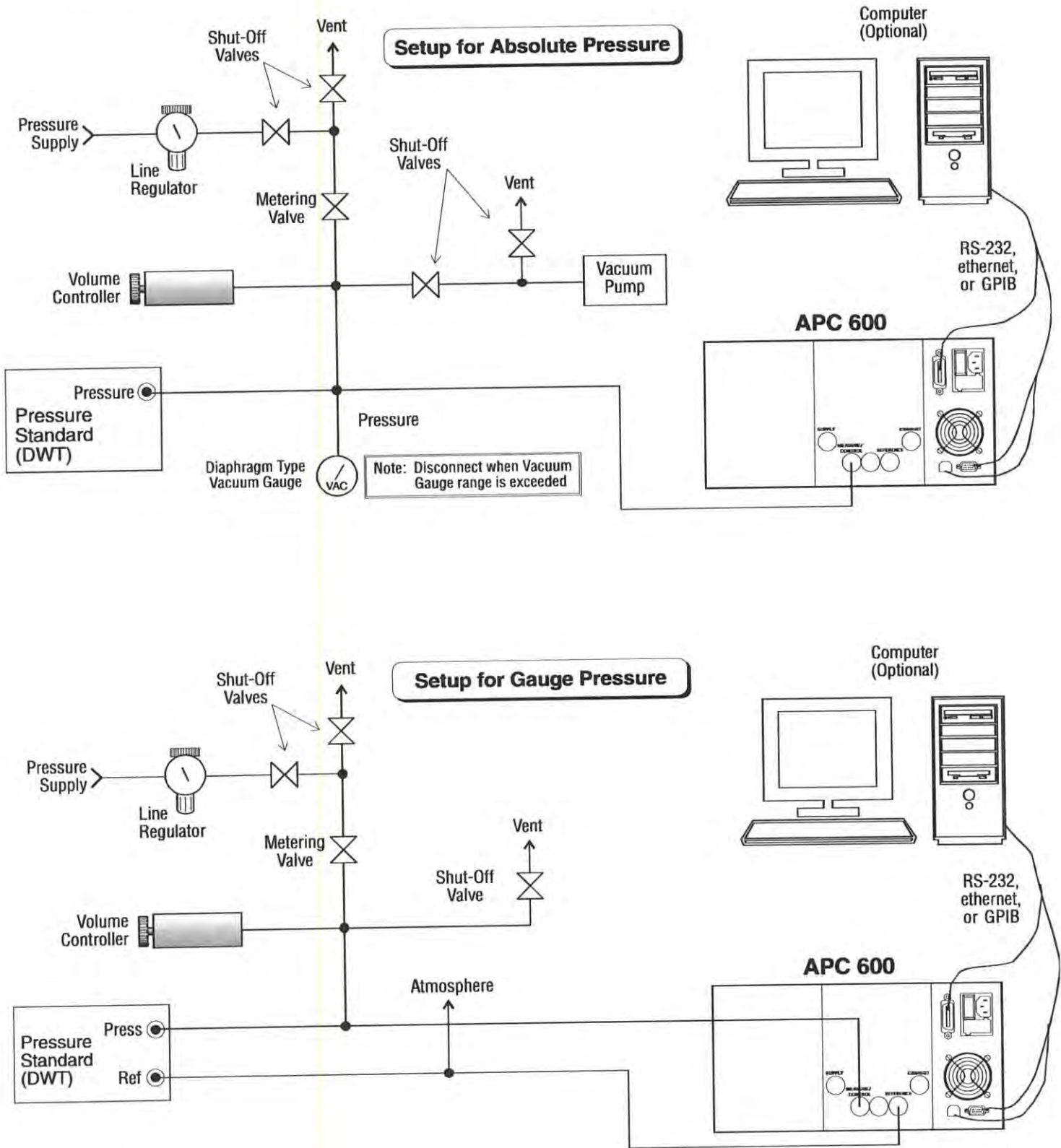

Figure 6.1 - Calibration Setup

PASSWORD

Autozero does not require a password, however one is needed to change any date of calibration, Zero, Span, or to change the system password. The password installed at the factory was 1 2 3 4 5 6, but the user can change this as described below.

Change Password

To change the current password:

1. Press the [Calibrate] key to see the Calibration Data screen similar to Figure 6.2. Notice the padlock.

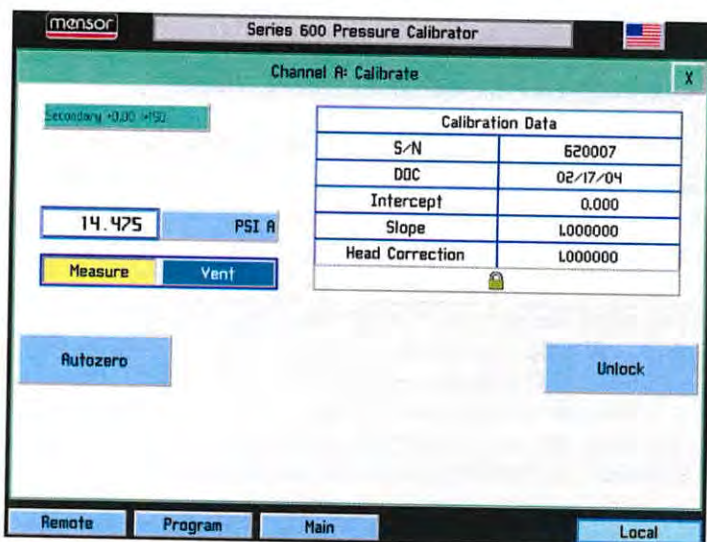



Figure 6.2 - Locked Calibration Data Screen

2. Touch the [Unlock] key to display the Enter Password screen as in Figure 6.3.
3. Enter the current password. As each number is pressed an '*' appears in the 'Password' window. When completed touch [OK] to unlock the calibration data screen.
4. The Calibration Data screen of Figure 6.4 is displayed. Use this screen to change DOC, Zero, Span, or the Password. Touch [Change Password] to see the Change Password window (Figure 6.5).
5. At the Change Password window enter from one to six digits for a new password (Figure 6.5). As each number is pressed it appears in the Password window.
6. Before proceeding, review the displayed digits for accuracy. A mistake here could prevent future access to this screen. To make a correction use [CE] to backspace through the entries and then immediately re-enter the correct numbers.



CAUTION: The password is seldom used and is easily forgotten. After a change write down and save the new number. If the password is lost, contact Mensor.

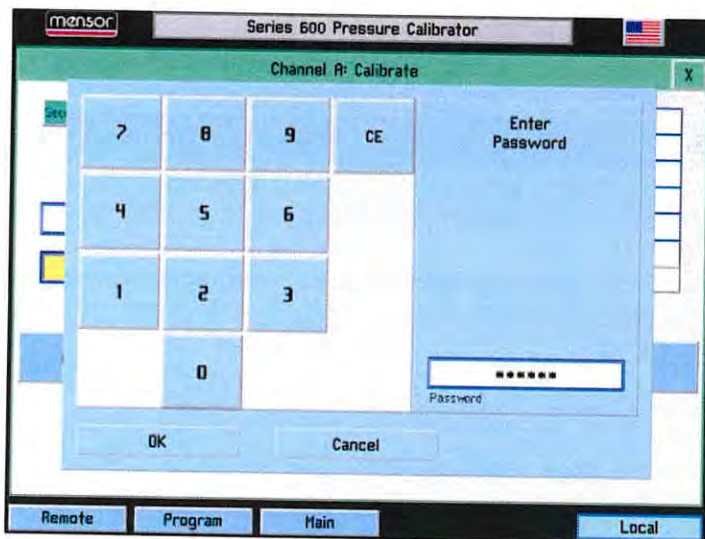

Figure 6.3 - 'Enter Password' Window

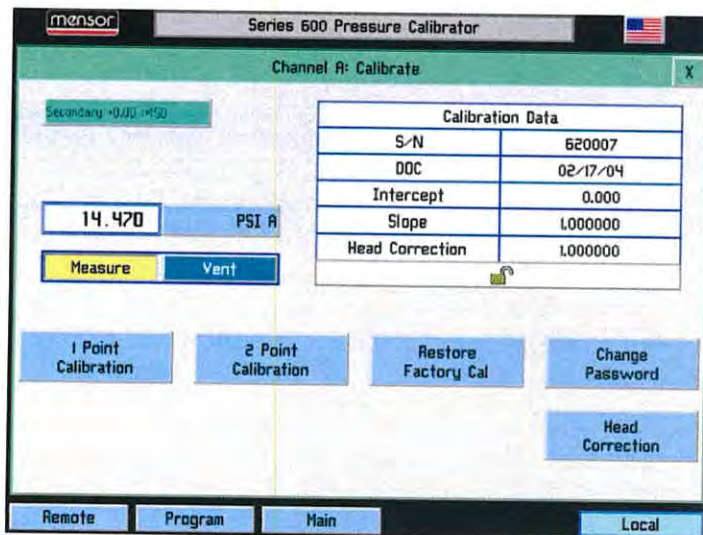

Figure 6.4 - Unlocked Calibration Data Screen

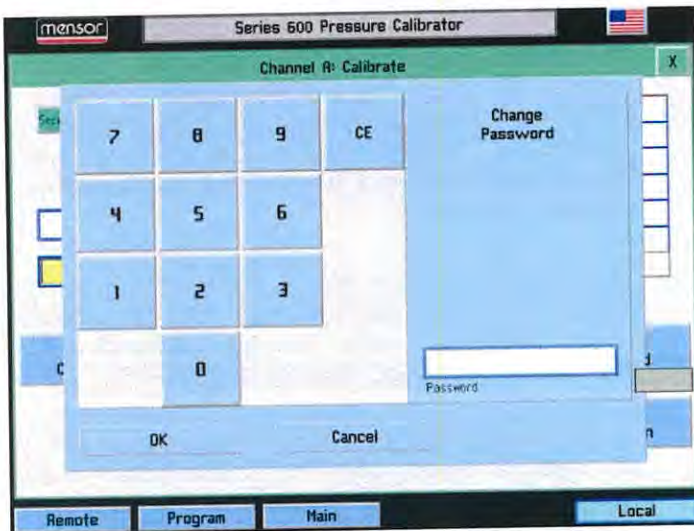

Figure 6.5 - 'Change Password' Window

7. When satisfied that the new password is correct, **and a written copy has been stored**, press [OK] to complete the entry. The previous password is immediately replaced by the new one.
8. Confirm that the new password is valid by pressing [Main], then repeat steps 1 through 3 to return to the Calibration Data screen (Figure 6.4). If this screen can't be accessed using either the old or the new password contact Mensor.

RESTORING A MENSOR CALIBRATION

The offset and slope values established for each turndown at the final factory calibration are stored in permanent memory within each transducer. These factory values can be restored at any time regardless of the the number of subsequent calibrations. To restore the factory calibration to the active turndown simply press [Restore Factory Cal] on the unlocked Data Entry screen seen in Figure 6.4. This will restore both the factory zero offset and slope calibration values to the active turndown. The [Restore Factory Cal] function can be repeated for each turndown as desired.

ON-SITE CALIBRATION

The APC 600 can contain one primary transducer and barometric reference and may have an additional, secondary transducer. Each transducer (except the Barometric Reference Transducer) can have up to two separately calibrated ranges (two turndowns). Zero and span adjustments are available for each of these turndowns.

Linearity is preset at the factory and is not adjustable. One and two point calibrations are used to make a linear correction to the pressure readings using the formula: (uncorrected reading) X slope) + offset. The one point calibration adjusts the offset, the two point calibration adjusts both the offset and the slope.

Procedure For On-Site Calibration

The following is a step-by step instruction for calibrating a selected turndown.

APC 600 Preparation

Evacuate the pressure transducer(s) to a low pressure that will still maintain a viscous flow, typically 600 millitorr (0.0116 psi). At pressures lower than this the pressure at any particular point in the system is questionable. Allow from five to ten minutes for the target pressure to stabilize, then convert the millitorr reading to an equivalent instrument reading in the active measurement units. Table 9.3 in the Appendix lists millitorr conversion factors.

To begin a calibration, press the [Calibrate] tab and unlock the calibration screen as described in the previous section. Select the turndown to calibrate from the drop list and the units in which to perform the calibration on the unlocked calibration data screen.

[Calibrate] Setup Key

The Calibration screen shown in Figure 6.6 is the first of several screens relating to the calibration functions. This screen allows the user to perform any of the following tasks:

1. Calibrate zero and span values on any turndown open of all installed sensors. An Absolute APC 600 allows calibration of the barometric reference transducer;
2. Establish a new Date of Calibration (DOC) for any turndown;
3. Change the system password;
4. Autozero all turndowns at one time.

Notice the padlock icon on the display. This signifies that the indicated values on the screen are not able to be modified until the password has been entered.

[Unlock] Key: Touch [Unlock] (Figure 6.6) to move on to the password screen. This function is password protected. Details on this function are included in the *Calibration* section.

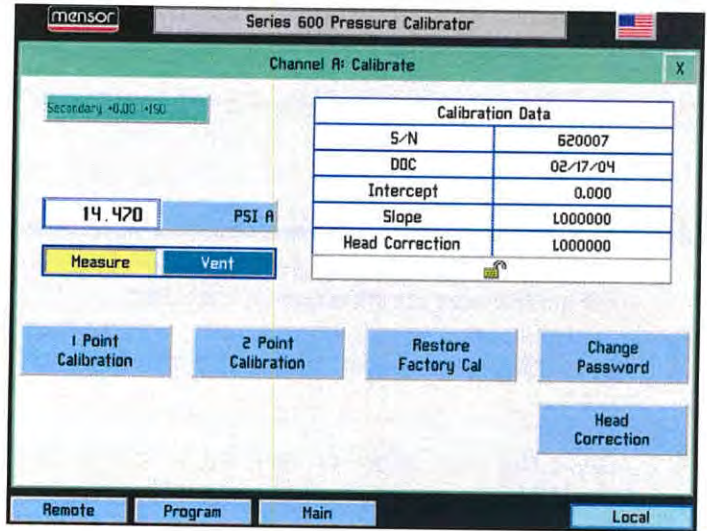

Figure 6.7 - Calibrate Screen (unlocked)

Date of Calibration Window: Information for the Date of Calibration (DOC) window is given under the sub-heading 'Password' in the *Calibration* section, including instructions for entering/changing the password.

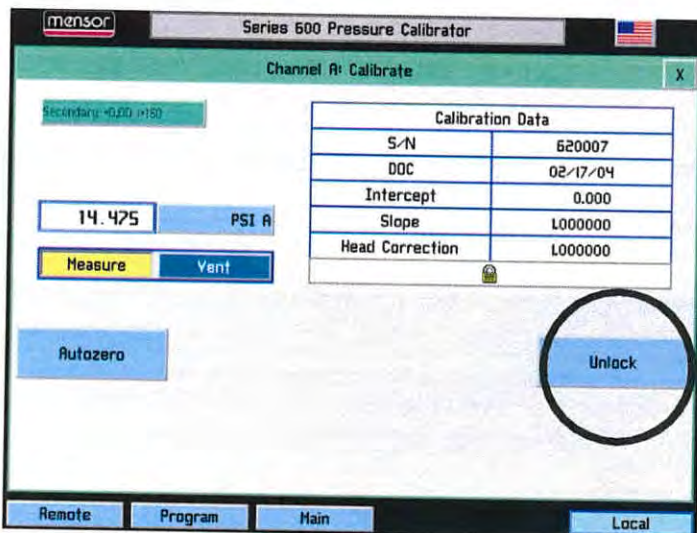

Figure 6.6 - Calibrate Screen (locked)

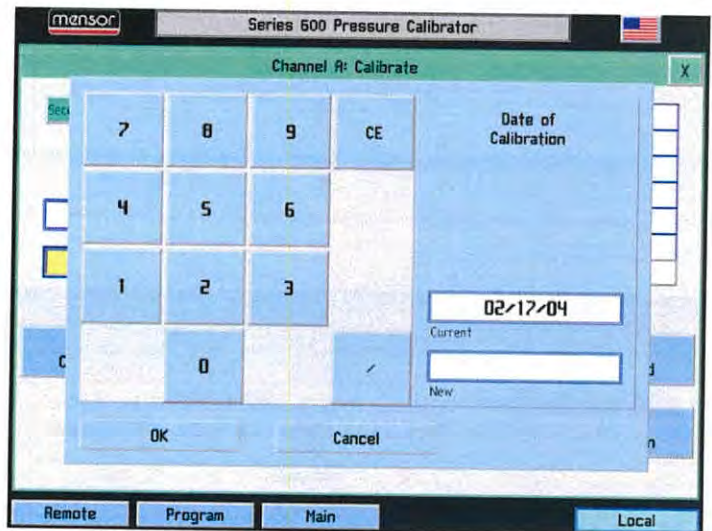

Figure 6.8 - Date of Calibration (DOC) Window

[Autozero] Key: Press this key to have the APC 600 automatically re-zero all turndowns that can measure the vented pressure (Figure 6.9).

For an absolute APC 600, this automatic function will:

1. Vent the system.
2. Select the turndown with the smallest span that can measure the vented pressure, or read the internal barometric reference if installed.
3. Record that pressure as "current barometric pressure".
4. Adjust the zero offset of each turndown so the turndown's output equals the "current barometric pressure".

For a gauge APC 600, this automatic function will:

1. Vent the system.
2. Adjust the zero offset of each turndown that can measure the vented pressure so the turndown's output is equal to zero.

NOTE: The autozero function re-zeros sensors without storing the zero offsets through power cycling.

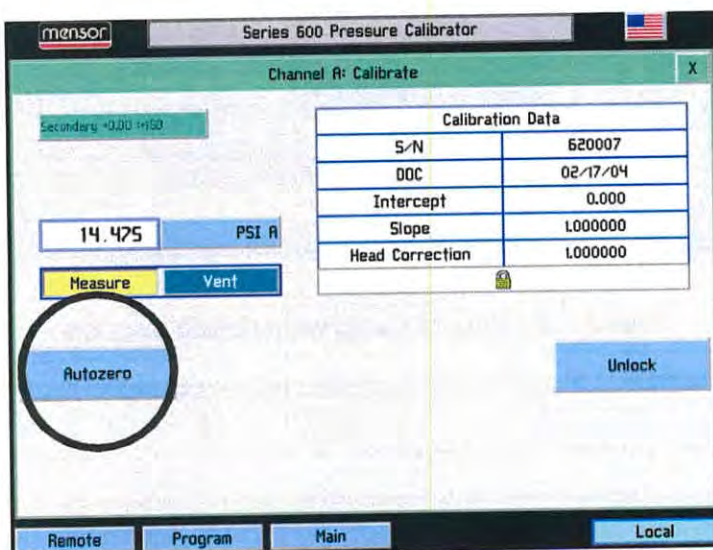

Figure 6.9 - Autozero

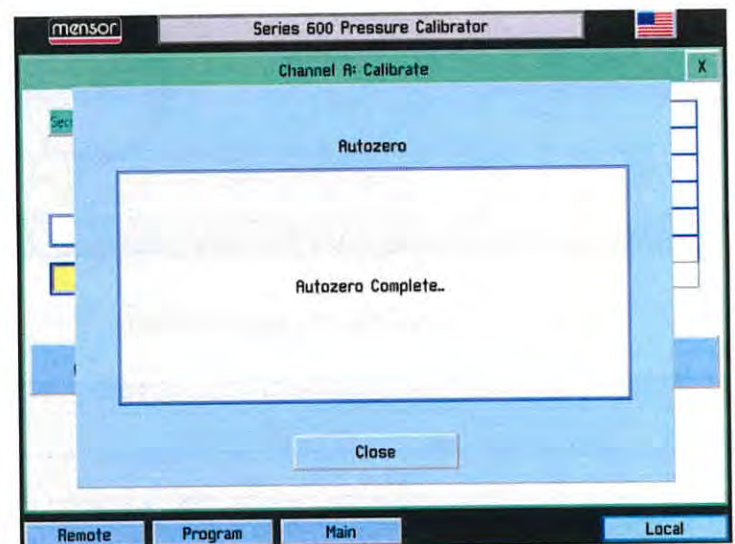

Figure 6.10 - Autozero Window

One Point Calibration

A one point calibration adjusts only the offset of the active turndown. From the unlocked calibration data screen, press the [1 Point Calibration] key (Figure 6.11). The '1 Point Cal' window illustrated in Figure 6.12 will appear. This window shows the maximum and minimum acceptable values and the current reading. The [?] key pops up a help dialog with instructions about how to use this screen. Enter the current known pressure in the 'Desired Reading' data window. Values entered that are outside of the displayed Maximum/Minimum limits will not be accepted. When the desired reading is displayed in the data window press the [OK] key and the offset will be stored. The [Cancel] key will exit this window and not make any adjustments to the calibration of the active turndown.

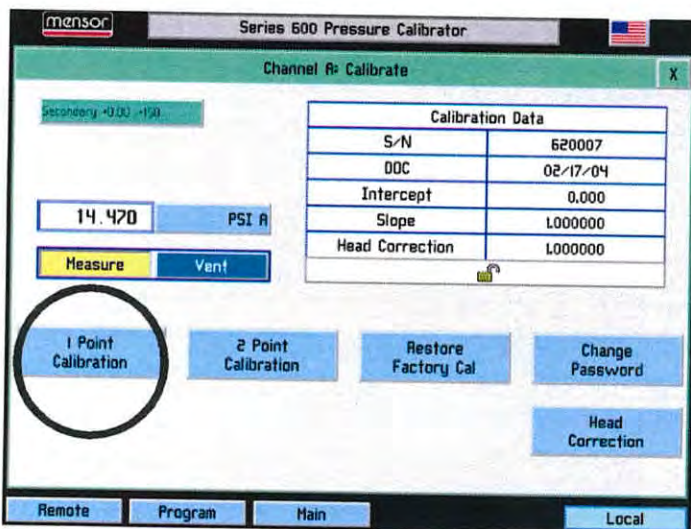

Figure 6.11 - '1 Point Cal' Key

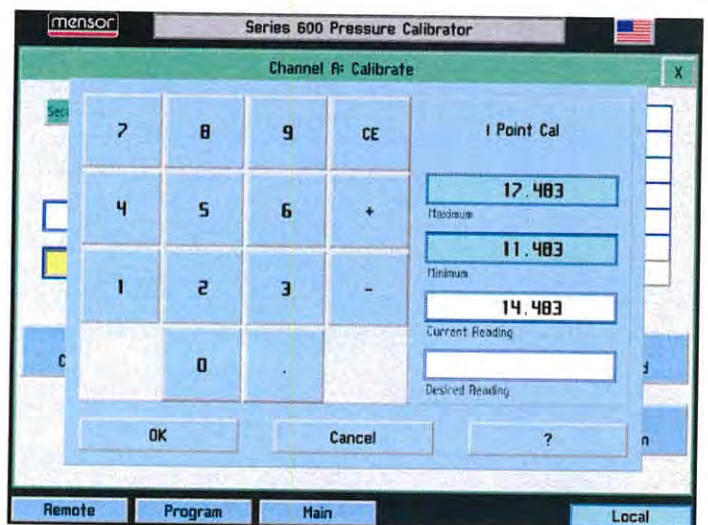

Figure 6.12 - '1 Point Cal' Window

Two Point Calibration

A two point calibration adjusts both the offset and the slope of the active turndown. The low point must be within 20% of the minimum range of the active turndown and the high point must be within 20% of the maximum range of the active turndown. From the unlocked calibration data screen, press the [2 Point Calibration] key as illustrated in Figure 6.13. The 'Low Point Cal' window illustrated in Figure 6.14 will appear. This window shows the maximum and minimum acceptable values and the current reading. The [?] key pops up a help dialog with instructions about how to use this window. Enter the current known pressure in the 'Desired Reading' data window and press the [OK] key.

The 'High Point Cal' window illustrated in Figure 6.15 will appear. It's function is identical to the 'Low Point Cal' window. Enter the new known pressure and press the [OK] key.

The [Cancel] key will exit either window and not make any adjustments to the calibration of the active turndown.

The 'Date of Calibration' window illustrated in Figure 6.16 will appear. Enter the date of calibration in a mm/dd/yyyy format exactly, including the '/' separation marks. Press the [OK] key and the new data of calibration will be saved to the turndown.

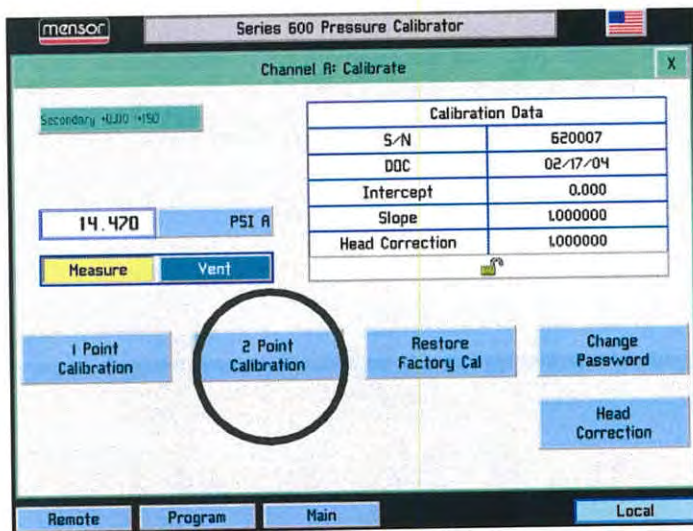

Figure 6.13 - '2 Point Cal' Key

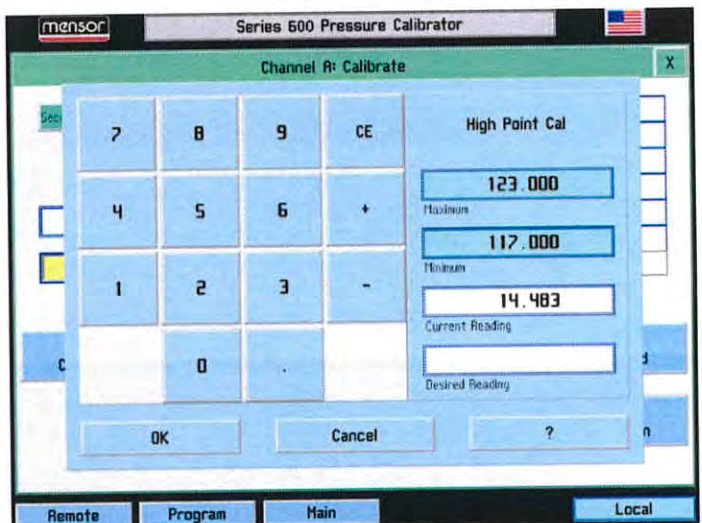

Figure 6.15 - 'High Point Cal' Window

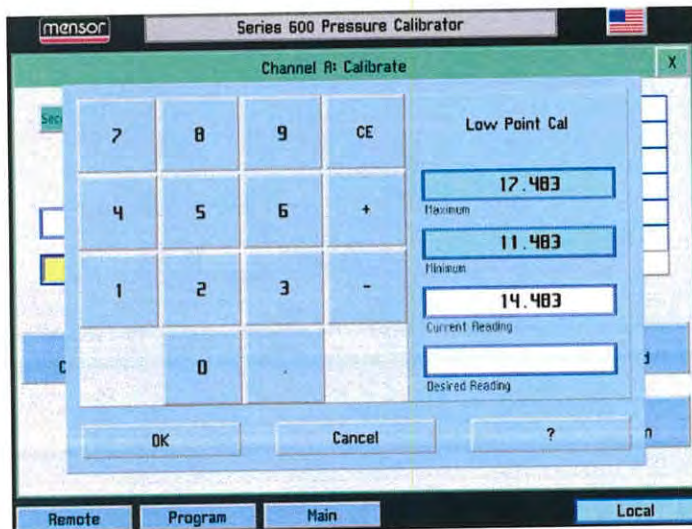

Figure 6.14 - 'Low Point Cal' Window

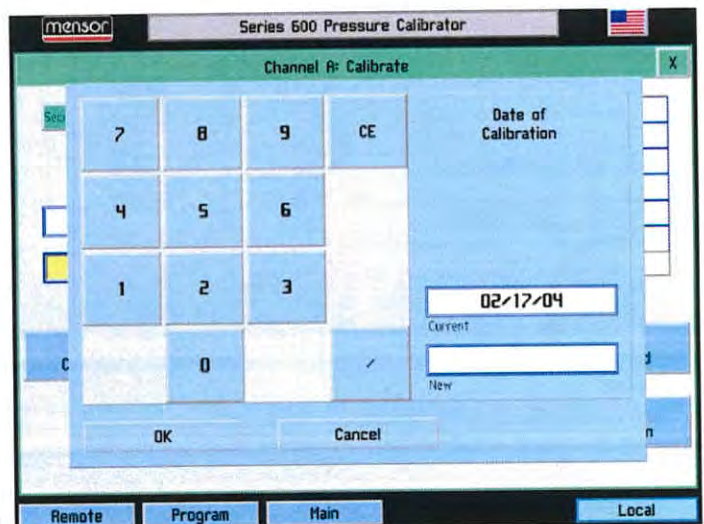

Figure 6.16 - 'DOC' Window

HEAD PRESSURE CORRECTION

The correction is accessed from the calibration menu. Four parameters may be set to reflect conditions at the operator's site. Press either [English] or [Metric] units for entering head pressure correction information into the APC 600. See Figure 6.17.

NOTE: Head correction parameters are stored separately for each channel.

Height: Enter the difference in height between the center of the measure/control port of the APC 600 and the reference level of the Device Under Test (DUT). If the reference level of the DUT is lower than the center

of the measure/control port of the APC 600, enter a positive height. If it is higher, enter a negative height. See Figure 6.18.

Gas Density: If nitrogen (N2) or dry air are being used as a pressure media, press the appropriate selection. If another gas is being used, enter the density for the gas at standard pressure and temperature in either lb/cubic foot (english) or kg/liter (metric) units. See Figure 6.19.

Gas Temperature: Enter the average gas temperature in degrees F or C. If unsure of the gas temperature use 68 F. See Figure 6.20.

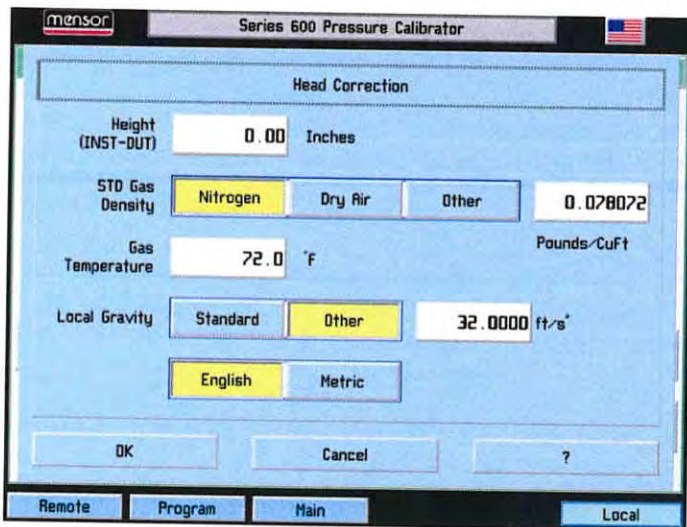

Figure 6.17 - Head Correction

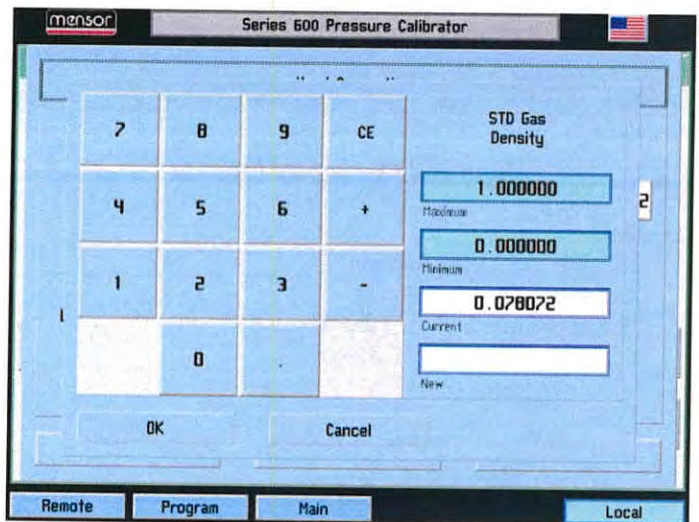

Figure 6.19 - Gas Density

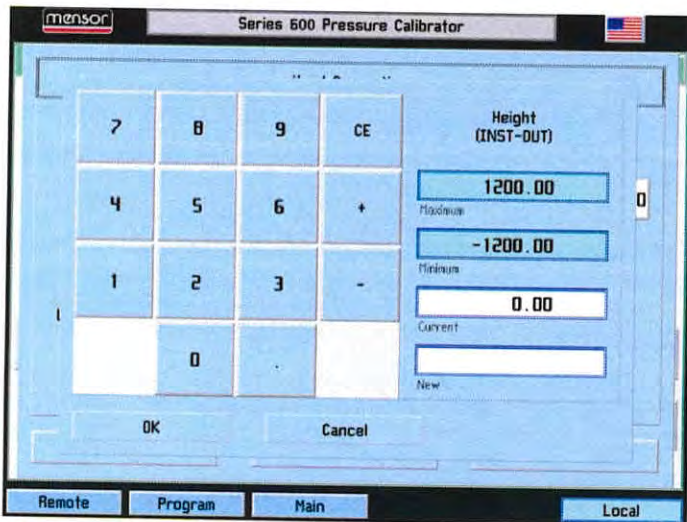

Figure 6.18 - Height

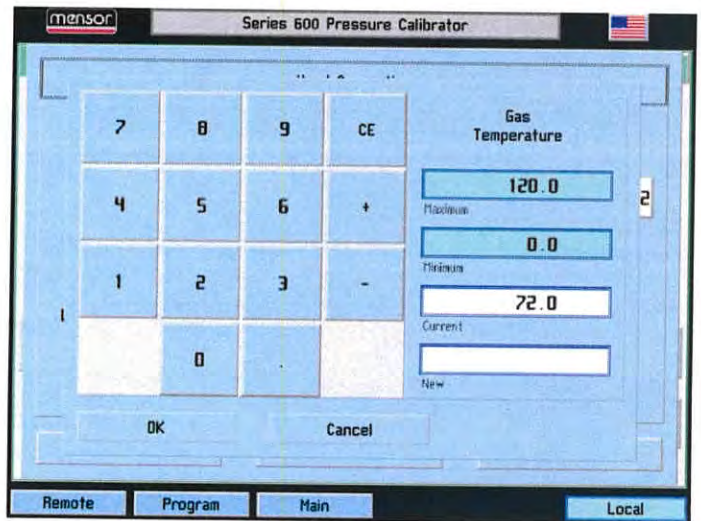

Figure 6.20 - Gas Temperature

Local Gravity: Enter the local gravity acceleration value. If unsure, use the standard gravity radio button. See Figure 6.21.

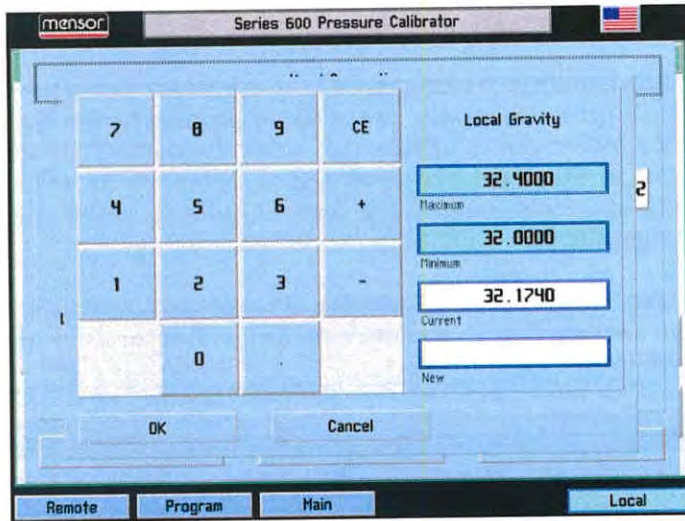

Figure 6.21 - Local Gravity

Limits:

Height: ± 1200 inches

Density: 0 to 1 lb/cu ft

Temperature: 0 to 120 °F

Gravity: 32 to 32.4 ft/sec²

Section 7: SPECIFICATIONS

Accuracy specifications presented herein are obtained by comparison with primary standards traceable to the National Institute of Standards and Technology (NIST). These specifications are obtained in accordance with the ISO *Guide to the Expression of Uncertainty in Measurement* (GUM). Mensor also adheres to ANSI/NCSL-Z540. If there is an exception to the requirements and recommendations of Z540 during a calibration the exception is noted on the individual calibration certificate.

Mensor reserves the right to change these specifications without notice.

MEASURE SPECIFICATIONS

Accuracy

0.01% FS for each turndown range. Uncertainties include all pressure effects, temperature effects and calibration stability over 180 days after re-zeroing.

Precision

0.003% of span

Pressure Ranges

0.36 to 1,500 psi. Specific ranges are selectable by the customer.

Measurement Units

psi, inHg@0°C and 60°F, inH₂O@4°C, 20°C and 60°F, ftH₂O@4°C, 20°C and 60°F, mTorr, inSW@0°C, ft SW@0°C, mSW@0°C, ATM, bar, mbar, mmH₂O@4°C and 20°C, cmH₂O@4°C and 20°C, MH₂O@4°C, mmH₂O@0°C, cmHg@0°C, Torr, hPa, kPa, Pa, Mpa, D/cm², G/cm², Kg/cm², OSI, PSF, TSF, TSI, μHg@0°C, %FS and 2 user-defined units. (See also "Measurement Units" Table in the *Appendix*, Section 9.)

Resolution

4 to 6 significant digits, user selectable.

CONTROL SPECIFICATIONS FOR LOW PRESSURE CONTROL MODULE

External Pressure Requirements

Source Requirements

Fast Mode: 10% over range of highest pressure transducer.

Slow Mode: None.

Note: Source pressure must be less than 30 psi. Performance can be enhanced with a well-regulated source pressure.

Exhaust Requirements

Fast Mode: A vacuum source is required for sub-atmospheric pressure control.

Slow Mode: None

Stability of Controlled Pressure

Fast and Slow Mode: 0.003% of span of active range - typically better than 0.001% of span 10 seconds after displaying stable flag.

Available Sensor Range

Fast Mode:

Absolute: 0 to 5 psia to 0 to 30 psia

Gauge: 0 to .36 psig to 0 to 15 psig

Bi-directional: -.18 to +.18 psi to -atm to 15 psig

Slow Mode:

Absolute: 0 to 5 psia to 0 to 30 psia

Gauge: 0 to .36 psig to 0 to 15 psig.

Minimum Controlled Pressure

Fast and Slow Mode: 0.05% FS or .05 psi over exhaust pressure, whichever is greater.

The minimum control point on absolute ranges is .5 psia.

Pressure Control Rates

Fast Mode: Fast control mode uses the roughing valves.

Slow Mode: Slow mode uses only the pump.

Control Time

Fast Mode: 10 seconds to stable flag for 10% FS step pressure change into a 50cc volume. Larger volumes can lengthen this time. Controlling to low absolute pressures will lengthen this time.

Slow Mode: 15 seconds to stable flag for 10% FS step pressure change into a 50cc volume. Larger volumes can lengthen this time. Controlling to pressures less than 0.5 psia will lengthen this time.

Supply Consumption

Fast Mode: Zero after setpoint is reached. All supply gas is used for upscale pressure sample filling.

Slow Mode: Zero

Measure to Control Offset

Fast and Slow mode: <0.0005% Span

Overshoot

< 1% of active range.

CONTROL SPECIFICATIONS FOR MID AND HIGH RANGE REGULATOR MODULE

External Pressure Requirements

Source Requirements

10% over range of highest pressure transducer or 20 psi over highest pressure transducer for a pressure channel, whichever is less.

Exhaust Requirements

A vacuum source is required for sub-atmospheric pressure control.

Stability of Controlled Pressure

0.003% of span on active range. Typically better than 0.001% of span 10 seconds after displaying stable flag.

Maximum Control Pressure

Mid Range: 150 psig

High Range: 1500 psig

Minimum Control Pressure

0.05% FS or .025 psi over exhaust pressure, whichever is greater.

Control Time

10 seconds to stable flag for any pressure change into 50cc volume. Larger volumes can lengthen this time. Controlling to pressures less than 0.5 psia can also lengthen this time.



Figure 7.1 - APC 600 Dimensions

Pressure Control Rates

Slow, Medium, Fast, Max (default).

Supply Consumption

<2.5 scfh in steady-state control.

Measure to Control Offset

<0.0005% Span

Overshoot

Low overshoot mode: <.005%

High speed mode: <1%

GENERAL SPECIFICATIONS**Size**

14.02" wide x 7.55" high x 12.42" deep (35.61 cm x 19.2 cm x 31.55 cm). See figure 7.1.

Weight

36 lbs. (16.33 kg) with all internal options.

Power Input Requirements

100-240 VAC, 47-63 Hz, 75 VA max.

Fuses: 1.5A, 230V, Type T

LITTLEFUSE 31301.5

Digital I/O

Pin 1 - +5 VDC, 100 mA max

Pin 2 - Output, pulled up to 5V with a 10k ohm resistor. Source limited to 450uA, Sink 10mA.

Pin 3 - Input protected by 200 ohm current limiting resistor. Voltage input should be limited to > -0.3 VDC and < +5.3 VDC.

Pin 4 - Ground

Pneumatic Interfaces

7/16" - 20 female SAE. 1/8" FNPT adapters provided.

Particle Filters

The instrument has 20-micron filters on all pressure ports through the manifold. The barometric transducer has no filters.

Pneumatic Overpressure Protection

Protected by relief valves.

Compensated Temperature Range

15°C to 45°C.

Operating Temperature Range

0°C to 50°C.

Note: This is not the compensated temperature range.

Storage Temperature Range

0°C to 70°C. Minimal vibration. Non-condensing humidity.

Local User Interfaces

8.4" color LCD display with 8 wire resistive touch screen.

Remote User Interfaces

RS-232, Ethernet, and IEEE-488.1 are standard.

Warm-up

Approximately 15 minutes to achieve full accuracy depending on environment.

Reading Rate

Typically 32 readings per second.

Response Time

<333 mS for FS step.

Orientation Effects

Negligible, can be removed with re-zeroing.

Shock/Vibration

2 gravities maximum per MIL-T-28800.

Operating Environment

5 to 95% RH non-condensing.

Pressure Media

Clean, dry, non-corrosive, non-combustible, non-oxidizing gases. Not suitable for oxygen use.

Compliance

The APC 600 is compliant to EN61326-1:A1:1998, EN61326-1:A2:2001, EN55024:1998, and EN61010-1-1.

Options

Transport Case.

Rack Mount Kit.

Calibration Sled Kit.

Secondary Transducer.

Barometric Reference Transducer.

Virtual Delta Channel.

User's Notes:

A large grid area for user notes, consisting of a 20x20 grid of small squares. The grid is intended for handwritten notes or calculations. A vertical yellow line is present on the left side of the grid, approximately one-fifth of the way from the left edge.

Section 8: OPTIONS

- Transport Case 8-1
- Rack Mount Kit 8-1
- Calibration Sled 8-1
- Additional Transducers 8-2
- Barometric Reference Transducer 8-2
- Virtual Delta Channel 8-3

This section lists options available for the APC 600. Users might consider letting the factory install a special feature not listed here. Mensor welcomes the opportunity to quote on such requests. The cost of adding an enhancement frequently will amortize itself in a very short time because of improved process efficiency.

TRANSPORT CASE (PN 0011159001)

A wheeled transport case is available suitable for moving the APC 600 between sites, or as an air-freight (or other) shipping container. The case is constructed of a high impact plastic with a black exterior. It includes two keys, locks, a piano hinge, an anodized interlocking tongue and groove opening, various nickel-chrome and stainless steel fixtures, a vinyl satchel style handle and a retractable pull-out handle. The interior is filled with high density polyurethane foam with a die-cut cavity to cradle the instrument with fitting adapters in place, and an additional cavity to store related accessories. Rugged and weather resistant, the case makes an attractive, practical shipping and moving container. The case weighs approximately 29 pounds (13.15 kg) unloaded, and can support a load of up to 150 pounds (68.04 kg). Nominal dimensions are 15 inches by 24 inches by 26 inches (38.10 cm x 60.96 cm x 66.04).

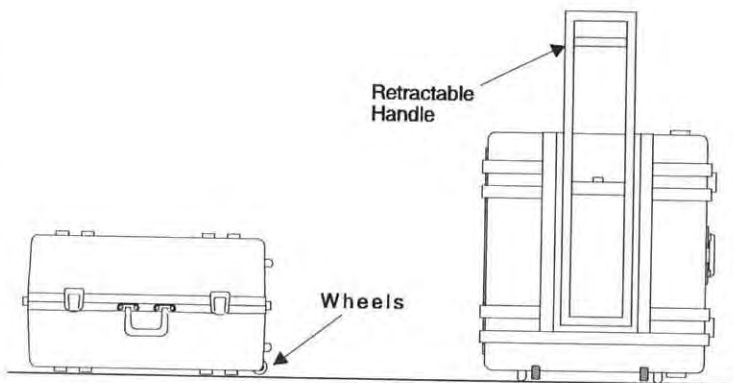

Figure 8.1 - Transport Case

RACK MOUNT KIT

A rack mount kit allows the customer to install an APC 600 into a standard 19" instrument rack. It includes pre-installed brackets on the sides of the instrument as well as spacer panels and hardware to rack mount the APC 600.



Figure 8.2 - Rack Mount Kit

CALIBRATION SLED

The calibration sled allows customers to calibrate transducers outside the APC 600. This allows the customer to continue using the other ranges inside the APC 600, while calibrating one of the transducers in order to reduce downtime. The Calibration Sled Kit includes the serial interface software, the Calibration Sled, a serial cable to connect the sled to the host computer, and a power supply (not pictured below) to power the Calibration Sled.



Figure 8.3 - Calibration Sled Kit

ADDITIONAL TRANSDUCERS

A secondary transducer of any standard range, and with up to two turndown ranges, can be purchased as an option. In all other regards, the add-on transducer will meet all of the specifications and operating parameters outlined throughout this manual.

NOTE: Each control channel has pressure control limits. Typically, the low pressure control modules have a maximum limit of 15 psig and the mid range control modules have limits of 150 or 1500 psig. If a sensor is placed into a control channel where the sensor has a higher upper pressure range than the control module, the maximum control limit will be limited to the maximum range of the control module.

While any sensor will function in any control channel, the results may not always be optimum. For example, if a 1 psi sensor is placed in a control module that has a 1500 psi upper limit, the controlled pressure stability may not be acceptable. Or if a 1500 psi module is placed in a control module that has a 30 psi upper limit, it will control very well, but be limited in resolution.

Secondary Transducer Installation

If the add-on transducer is of a higher full scale range than the existing Primary Transducer, then this newer transducer becomes the Primary, and the existing transducer must be moved to the Secondary Transducer berth. For complete installation instructions see the text under "Transducer Replacement" in Section 5, *Maintenance*.

BAROMETRIC REFERENCE TRANSDUCER

The Barometric Reference Transducer is a very stable, absolute pressure device used to accurately measure local atmospheric pressure.

The APC 600 will use the barometric pressure measured by the installed barometric reference sensor in the current channel. If only one barometric sensor is installed, its measurement is shared by both channels.

Gauge Pressure Emulation Key

On absolute units set the APC 600 for gauge pressure measurement and control by touching [Pressure Units]

which will display the Units pop-up window shown in Figure 3.6. In the upper right corner of this window is an [Absolute/Gauge] toggle key. Press [Absolute] to change to [Gauge], then press [OK]. The operation screen now shows Units [GE] in place of Units [A]. The "GE" indicates that the measurement and control values are in Gauge Emulation pressure units.

In the Gauge Emulation mode the atmospheric pressure reading from the barometric reference transducer is subtracted from the absolute pressure reading of the active channel to emulate a gauge pressure.

The barometric reference sensor has six significant digits. If a very low pressure gauge sensor is active and is used in absolute emulation, the combined output may appear quite noisy because of the resolution of the barometric reference.

Emulation mode uncertainty is the combined uncertainty of the barometric reference transducer and the active transducer.

Absolute Pressure Emulation Key

On gauge units set the APC 600 for absolute pressure measurement and control by touching [Pressure Unit] which will display the Units pop-up window. In the upper right corner of this window is an [Absolute/gauge] toggle key. Press [Gauge] to change to [Absolute], then press [OK]. The operation screen now shows Units [AE] in place of Units [G]. The "AE" indicates that the measurement and control values are in absolute emulation pressure units.

In Absolute Emulation mode the atmospheric pressure reading from the Barometric Reference Transducer is added to the gauge pressure reading of the active channel to emulate absolute pressure.

Calibration

The Barometric Reference Transducer can be calibrated in exactly the same manner as the other installed sensors as described in Section 6, *Calibration*.

Specifications

Accuracy: 0.01% of reading. Uncertainties include all pressure effects, temperature effects over the calibrated range and calibration stability for six months after re-zeroing.

Pressure Range: Calibrated from 11 to 17 psia.
Resolution: 6 digits.

VIRTUAL DELTA CHANNEL

Delta Functions

Two virtual delta functions are available: A-B and B-A. The delta functions are strictly a mathematical difference between the two physical channel readings. There is no pressure connection between the channels.

Screen Source

The APC 600 has two frames in which channel information can be displayed. The frame channel source can be programmed to A(left) B(right) or A(left) Delta(right) or Delta(left) B(right). Either frame can be minimized as before.

Configure Button

In order to allow the delta function and frame channel source to be changed, a new button was added to the lower toolbar. This button is labeled CONFIGURE. Pressing this button brings up a window with radio buttons to select the desired configuration as shown in Figure 8.4.

Slave Channel Display

Since the range information is not applicable to the delta channel, the slave channel (the physical one not displayed) reading is displayed where the range droplist appears in the normal screen.

Screen Source A B

Channels are completely independent. Operates just like a standard APC 600.

Screen Source A Delta

A is displayed on the left and is the leading channel. Delta is displayed on the right and is either A-B or B-A as selected. Channel B's reading is displayed where the range information normally appears on the Delta channel. Channel B is the slave channel. Whenever the A channel is changed, the B channel setpoint is changed to maintain the differential setpoint displayed on the Delta channel. Whenever the Delta channel setpoint is changed, the B setpoint is changed as well.

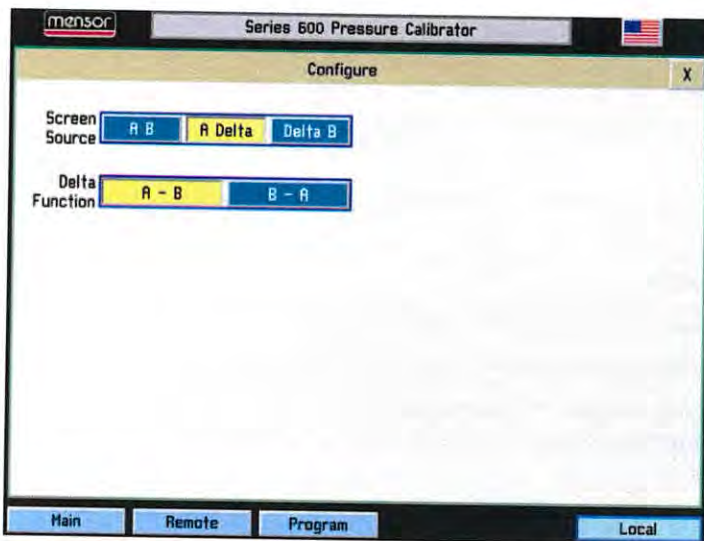

Figure 8.4 - Configure Button Display Screen

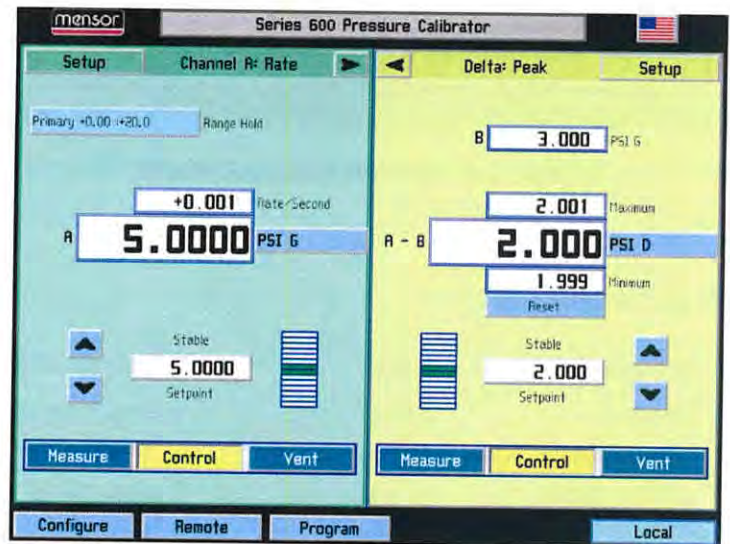

Figure 8.5 - Screen Source A Delta

Screen Source Delta B

Delta is displayed on the left and is either A-B or B-A as selected. B is displayed on the right and is the leading channel. Channel A's reading is displayed where the range information normally appears on the Delta channel. Channel A is the slave channel. Whenever the B channel is changed, the A channel setpoint is changed to maintain the differential setpoint displayed on the Delta channel. Whenever the Delta channel setpoint is changed, the A setpoint is changed as well.

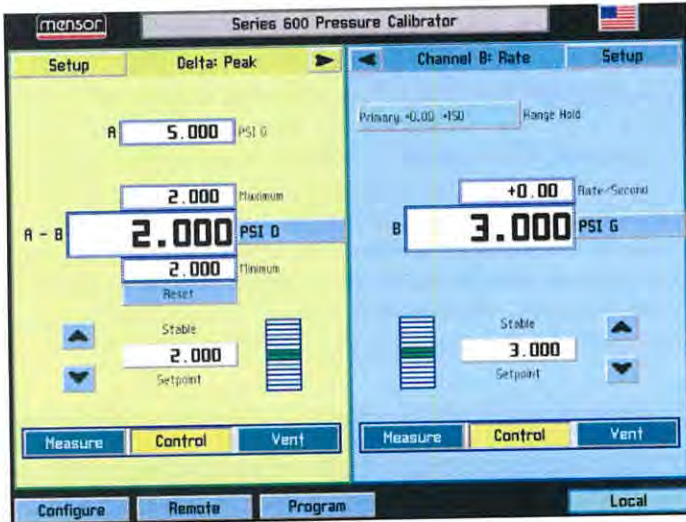

Figure 8.6 - Screen Source Delta B

Delta Control Limits

The default control limits for the Delta channel are the maximum limits possible. Certain combinations of setpoints will generate an illegal setpoint on the slave channel. Note that whether or not the setpoint is illegal is dependent on the measured reading of the leading channel. In order to prevent the APC 600 from rejecting control points that may become legal in the future, all possible setpoints are allowed unless restricted by setting the control limits to other values.

Delta Units Type

The delta units type is Differential and a D appears after the units label. Emulation is not available on the delta channel. If channel A and B are not set to the same pressure type, the delta reading may be ambiguous.

Setup Screens

The delta channel does not have the following setup buttons: STATUS, CAL, TEST, CONTROL CAL, control parameters except limits and stable. To change parameters on the slave channel, you must select the A,B (normal) screen source.

New Commands

Command	Data	Function/Response
CHAN D	None	Sets the active channel to the Differential channel.
SCREENSRC A,B	None	Sets the APC 600 to normal operation screen displaying A and B channels.
SCREENSRC A,Delta	None	Sets the APC 600 to display A channel as normal, and Delta channel replaces the B channel location. In this mode the "A" channel is considered the leading channel.
SCREENSRC Delta,B	None	Sets the APC 600 to display B channel as normal, and Delta channel replaces the A channel location. In this mode the "B" channel is considered the leading channel.
SCREENSRC?	<sp>{A,B or A,Delta or Delta,B}<cr><lf>	Returns screen source as one of the above options.
*DELTAFUNC A-B	None	Sets the delta to be the result of the channel A reading – channel B reading.
*DELTAFUNC B-A	None	Sets the delta to be the result of the channel B reading – channel A reading.
*DELTAFUNC?	<sp>{A-B or B-A}<cr><lf>	Returns delta function as one of the above options.

*NOTE: Chan D must be the active channel.

Section 9: APPENDIX

MEASUREMENT UNITS

The Units command selects the measurement units to be output on the bus and the display.

Table 9.1 – Measurement Units (unitno)

Code	Description	Output Format
1	pounds per square inch	PSI
2	inches of mercury @ 0°C	inHg 0°C
3	inches of mercury @ 60°F	inHg 60°F
4	inches of water @ 4°C	inH ₂ O 4°C
5	inches of water @ 20°C	inH ₂ O 20°C
6	inches of water @ 60°F	inH ₂ O 60°F
7	feet of water @ 4°C	ftH ₂ O 4°C
8	feet of water @ 20°C	ftH ₂ O 20°C
9	feet of water @ 60°F	ftH ₂ O 60°F
10	millitorr	mTorr
11	inches of seawater @ 0°C 3.5% salinity	inSW
12	feet of seawater @ 0°C 3.5% salinity	ftSW
13	atmospheres	ATM
14	bars	Bar
15	millibars	mBar
16	millimeters of water @ 4°C	mmH ₂ O 4°C
17	centimeters of water @ 4°C	cmH ₂ O 4°C
18	meters of water @ 4°C	MH ₂ O 4°C
19	millimeters of mercury @ 0°C	mmHg 0°C
20	centimeters of mercury @ 0°C	cmHg 0°C
21	torr	Torr
22	kilopascals	kPa
23	pascals	PA
24	dyne per square centimeter	Dy/cm ²
25	grams per square centimeter	gm/cm ²
26	kilograms per square centimeter	kg/cm ²
27	meters of seawater @ 0°C 3.5% salinity	MSW
28	ounce per square inch	OSI
29	pounds per square foot	PSF
30	tons per square foot	TSF
31	percent of full scale	%FS
32	micron HG @ 0°C	uHg 0°C
33	ton per square inch	TSI
34	n/a	n/a
35	hectopascals	hPa
36	megapascals	MPa
37	millimeters of water @ 20°C	mmH ₂ O 20°C
38	centimeter of water @ 20°C	cmH ₂ O 20°C
39	meters of water @ 20°C	MH ₂ O 20°C
n/a	User Units 1	User defined
n/a	User Units 2	User defined

CONVERSION FACTORS, PSI

The values listed in the column **To convert from psi** are the values imbedded in the instrument program. The values listed under **To convert to psi** are internally calculated approximations based on the imbedded values.

Table 9.2 – Conversion Factors, PSI

Code	Pressure Unit	To convert from PSI	To convert to PSI
1	PSI	1	1
2	INHG @ 0C	2.036020	0.4911544
3	INHG @ 60F	2.041772	0.4897707
4	INH2O @ 4C	27.68067	0.03612629
5	INH2O @ 20C	27.72977	0.03606233
6	INH2O @ 60F	27.70759	0.03609119
7	FTH2O @ 4C	2.306726	0.4335149
8	FTH2O @ 20C	2.310814	0.4327480
9	FTH2O @ 60F	2.308966	0.4330943
10	MTORR	51715.08	0.00001933672
11	INSW @ 0C 3.5% salinity	26.92334	0.03714250
12	FTSW @ 0C 3.5% salinity	2.243611	0.445710
13	ATM	0.06804596	14.69595
14	BAR	0.06894757	14.50377
15	MBAR	68.94757	0.01450377
16	MMH2O @ 4C	703.0890	0.001422295
17	CMH2O @ 4C	70.30890	0.01422295
18	MH2O @ 4C	0.7030890	1.422295
19	MMHG @ 0C	51.71508	0.01933672
20	CMHG @ 0C	5.171508	0.1933672
21	TORR	51.71508	0.01933672
22	KPA	6.894757	0.1450377
23	PA	6894.757	0.0001450377
24	DYNE/SQ CM	68947.57	0.00001450377
25	G/SQ CM	70.30697	0.01422334
26	KG/SQ CM	0.07030697	14.22334
27	MSW @ 0C 3.5% salinity	0.6838528	1.462303
28	OSI	16	0.0625
29	PSF	144	0.006944444
30	TSF	0.072	13.88889
31	% FS	(PSI / RANGE) x 100	(% FS x RANGE) / 100
32	MICRON HG @ 0C	51715.08	0.00001933672
33	TSI	0.0005	2000
35	HPA	68.94757	0.01450377
36	MPA	0.006894757	145.0377
37	MMH2O @ 20C	704.336	0.001419777
38	CMH2O @ 20C	70.4336	0.01419777
39	MH2O @ 20C	0.704336	1.419777

CONVERSION FACTORS, MILLITORR

The following table lists factors which should be used as multipliers when converting other pressure units to or from millitorr.

Table 9.3 – Conversion Factors, millitorr

Code	Pressure Unit	To convert from millitorr	To convert to millitorr
1	PSI	0.00001933672	51715.08
2	INHG @ 0C	0.00003936995	25400.08909
3	INHG @ 60F	0.00003948117	25328.53093
4	INH2O @ 4C	0.0005352534	1868.273977
5	INH2O @ 20C	0.0005362028	1864.966281
6	INH2O @ 60F	0.0005357739	1866.458778
7	FTH2O @ 4C	0.00004460451	22419.25773
8	FTH2O @ 20C	0.00004468356	22379.59744
9	FTH2O @ 60F	0.00004464783	22397.50637
10	MTORR	1.0	1.000000022
11	INSW @ 0C 3.5% salinity	0.0005206091	1920.827359
12	FTSW @ 0C 3.5% salinity	0.00004338408	23049.92831
13	ATM	0.000001315786	760002.2299
14	BAR	0.000001333220	750063.6259
15	MBAR	0.001333220	750.0636259
16	MMH2O @ 4C	0.0135954	73.5540997
17	CMH2O @ 4C	0.001359544	735.5409971
18	MH2O @ 4C	0.00001359544	73554.09971
19	MMHG @ 0C	0.001	1000.000022
20	CMHG @ 0C	0.0001	10000.00022
21	TORR	0.001	1000.000022
22	KPA	0.0001333220	7500.636259
23	PA	0.1333220	7.500636259
24	DYNE/SQ CM	1.333220	0.750063626
25	G/SQ CM	0.001359506	735.561166
26	KG/SQ CM	0.000001359506	735561.166
27	MSW @ 0C 3.5% salinity	0.00001322347	75623.11663
28	OSI	0.0003093875	3232.1992
29	PSF	0.002784488	359.132477
30	TSF	0.000001392244	718265.0575
32	MICRON HG @ 0C	1.0	1.000000022
33	TSI	n/a	n/a
35	HPA	0.001333220	750.0636259
36	MPA	0.0000001333220	7500636.259
37	MMH2O @ 20C	0.01361955	73.42388114
38	CMH2O @ 20C	0.001361955	734.2388114
39	MH2O @ 20C	0.00001361955	73423.88114

CONVERSION FACTORS, PASCAL

The following table lists factors which should be used as multipliers when converting other pressure units to or from Pascal.

Table 9.4 – Conversion Factors, Pascal

Unit No.	Pressure Unit	To convert from Pascal	To convert to Pascal
1	PSI	1.450377E-04	6.894757E+03
2	INHG @ 0C	2.952997E-04	3.386390E+03
3	INHG @ 60F	2.961339E-04	3.376850E+03
4	INH2O @ 4C	4.014741E-03	2.490820E+02
5	INH2O @ 20C	4.021862E-03	2.486410E+02
6	INH2O @ 60F	4.018645E-03	2.488400E+02
7	FTH2O @ 4C	3.345622E-04	2.988980E+03
8	FTH2O @ 20C	3.351551E-04	2.983692E+03
9	FTH2O @ 60F	3.348871E-04	2.986080E+03
10	MTORR	7.500636E+00	1.333220E-01
11	INSW@ 0C 3.5% sal	3.904899E-03	2.560885E+02
12	FTSW@ 0C 3.5% sal	3.254082E-04	3.073062E+03
13	ATM	9.869230E-06	1.013250E+05
14	BAR	1.00000E-05	1.00000E+05
15	MBAR	1.00000E-02	1.00000E+02
16	MMH2O @ 4C	1.019744E-01	9.806378E+00
17	CMH2O @ 4C	1.019744E-02	9.806378E+01
18	MH2O @ 4C	1.019744E-04	9.806378E+03
19	MMHG @ 0C	7.500636E-03	1.333220E+02
20	CMHG @ 0C	7.500636E-04	1.333220E+03
21	TORR	7.500636E-03	1.333220E+02
22	KPA	1.00000E-03	1.00000E+03
23	PA	1.00000E+00	1.00000E+00
24	DYNE/SQ CM	1.00000E+01	1.00000E-01
25	G/SQ CM	1.019716E-02	9.806647E+01
26	KG/SQ CM	1.019716E-05	9.806647E+04
27	MSW @ 0C 3.5% sal	9.918444E-05	1.008222E+04
28	OSI	2.320603E-03	4.309223E+02
29	PSF	2.088543E-02	4.788025E+01
30	TSF	1.044271E-05	9.576052E+04
32	MICRON HG @ 0C	7.500636E+00	1.333220E-01
33	TSI	7.251885E-08	1.378951E+07
35	HPA	1.00000E-02	1.00000E+02
36	MPA	1.00000E-06	1.00000E+06
37	MMH2O @ 20C	1.021553E-01	9.789017E+00
38	CMH2O @ 20C	1.021553E-02	9.789017E+01
39	MH2O @ 20C	1.021553E-04	9.789017E+03

User's Notes:

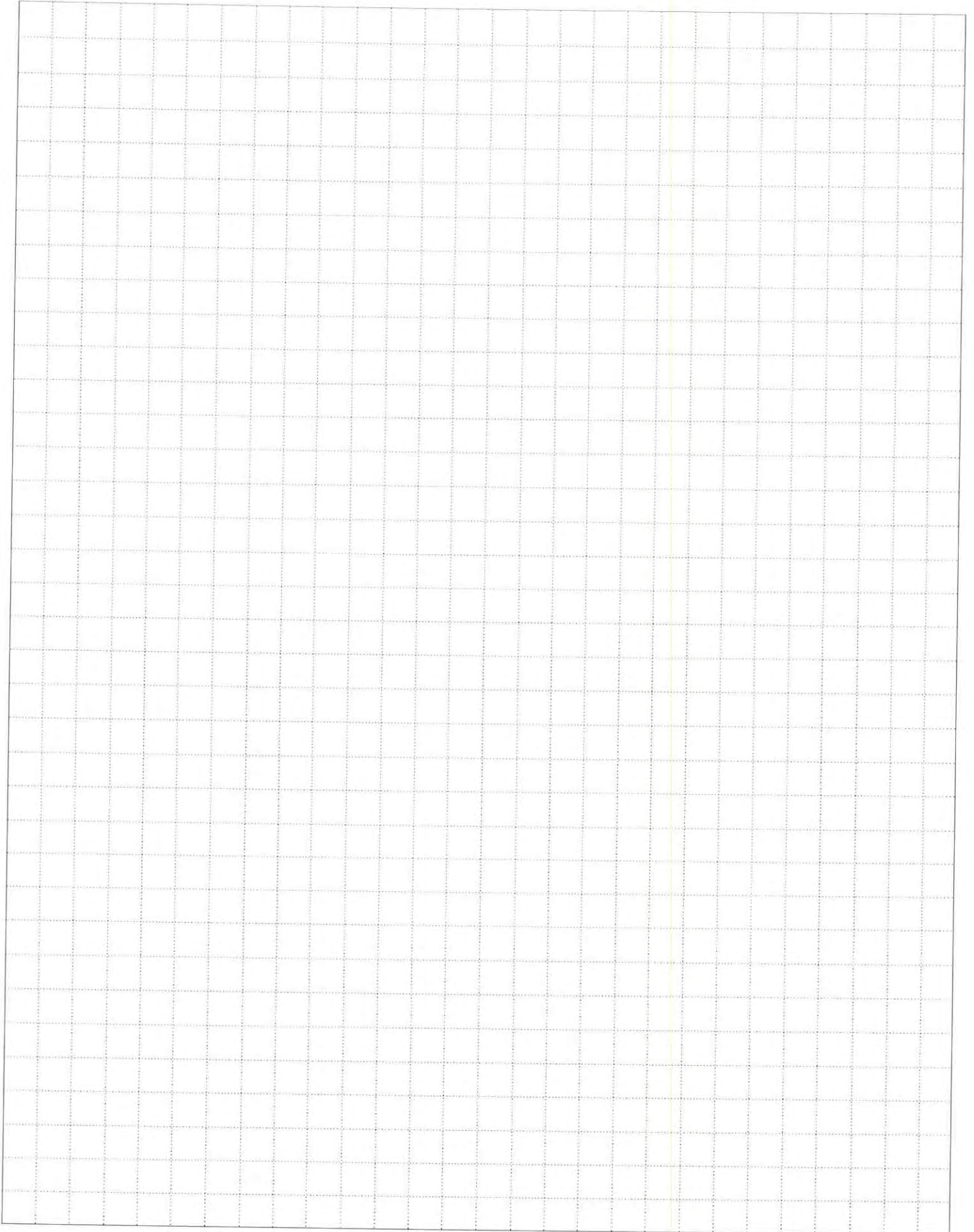



MENSOR CORPORATION
201 BARNES DRIVE
SAN MARCOS, TEXAS 78666-5994

Phone: 512.396.4200

Fax: 512.396.1820

Web site: www.mensor.com

E-mail: sales@mensor.com